



Irbit Motorcycle Factory

Irbit Motorworks of America



Owners Manual

2005 Model

Gear Up, Patrol, Tourist, Troyka

Contents

Introduction	7
Warnings, Cautions, Notes	9
Chapter 1 Specifications	
Specifications	11
Torque Specifications	15
Chapter 2 Motorcycle Controls and Instruments	
Motorcycle Controls & Instrumentation	17
Controls	17
Control and Instrument maintenance	25
Chapter 3 Engine Operation	
Engine Operation and Maintenance	27
Pre-Trip Preliminaries	27
Starting the Engine	27
Operating Precautions	31
Running-In the New Motorcycle	32
Chapter 4 Engine Design	
Brief Description of Design	33
Lubrication System	34
Fuel System	35
Ignition System	37
Chapter 5 Carburetors	
Carburetors	39
Carburetor Maintenance	40
Chapter 6 Power Transmission	
Power Transmission	41
Clutch	41
Gearbox	41
Final Drive	42

Chapter 7 Running Gear

Running Gear	43
Motorcycle and Sidecar Frames	43
Spring-Loaded Hydraulic Shock Absorber	44
Adjustment of Sidecar Installation	45
Front Fork	46
Steering Head Bearings.....	48

Chapter 8 Wheel & Tires

Wheels and Tires	49
Tire Data	50
Running Gear Maintenance	51

Chapter 9 Brakes

Brakes	53
Brake Adjustment	53

Chapter 11 Electrical

Electrical Equipment	57
Electrical Circuits.....	59
Electrical Equipment Maintenance	59
Wiring Diagram	60

Chapter 12 Maintenance

Maintenance of Motorcycle	61
List of Recommended Lubricants	61
Lubrication Chart	63
Required Lubrication	64
Care of Motorcycle Paint	64
Preservation and Storage	65
Battery	65
List of Individual Tool Set, Spare Parts, Accessories & Documents	66

Chapter 13 Gear-Up & Patrol Motorcycle With Engageable Sidecar Drive

Patrol Motorcycle with Engageable Sidecar Drive	69
Description	69
Handling Differences from the Single Wheel Drive	69
Sidecar Maintenance	70

Chapter 14 Learning to Ride the URAL

Learning to Ride the Ural Motorcycle with Sidecar Accessory	71
Safe Operating Rules	73

Chapter 15 Warranty

Warranty	75
----------------	----

Chapter 16 Service Coupons

Service Coupons	82
New Address Form	92
New Owner Form	93
URAL Starting and Running Tips	94

INTRODUCTION

Welcome to the URAL Motorcycling Family! Your Ural has been built by the Irbit Motorcycle Factory in Russia and distributed by Irbit Motorworks of America, the United States affiliate of the Irbit Motorcycle Factory. The Ural motorcycle conforms to all applicable US Federal Motor Vehicle Safety Standards and US Environmental Protection Agency regulations effective on the date of manufacture. This manual covers the Gear-Up, Patrol, and Tourist models.

This manual has been prepared to acquaint you with the operation, care and maintenance of your motorcycle, and to provide you with important safety information. Follow these instructions carefully for maximum motorcycle performance and for your personal motorcycling safety and pleasure. Please pay particular attention to the section "Learning to Ride the Ural Motorcycle with Sidecar". It is critical that a beginning sidecar driver becomes thoroughly familiar with the special operating characteristics of sidecar outfits before venturing out on the busy roads.

Your Owner's Manual contains instructions for operation, maintenance and minor repairs. Major repairs require the attention of a skilled mechanic and the use of special tools and equipment. Your Authorized IMWA Ural Dealer has the facilities, experience and genuine Ural parts necessary to properly render this valuable service.

Any suggestions or comments are welcome! Write to us or post an e-mail on the Ural Discussion bulletin board at **www.imz-ural.com**.

Happy Riding!

Important Notice!

Statements in this manual preceded by the following words are of special importance:

WARNING: *MEANS THERE IS THE POSSIBILITY OF PERSONAL INJURY TO YOURSELF OR OTHERS.*

CAUTION: *Means there is the possibility of damage to the vehicle.*

NOTE: *Other information of particular importance has been placed in italic type.*

CAUTION! *During the initial 1,500 km, a fundamental bedding-in of parts for all the mechanisms of the motorcycle takes place. During this period do not race, overload, or lug the engine.*

Note the riding procedures described in the section “Running-In of New Motorcycle.”

Following those procedures will ensure that you have the most powerful & smoothly operating engine after break-in.

Maintenance intervals recommended are based on operational experience under various climatic and road conditions. However, these intervals may be modified following repeated checks of the lubricant condition and general mechanical condition of the motorcycle.

Carefully study this Owner’s Manual before starting the motorcycle.

Specifications and design are subject to change without notice.

Chapter 1

SPECIFICATIONS

GENERAL

	Patrol & Gear-Up	Tourist
Maximum speed of motorcycle	95 km/h 59 mph	105 km/h 65 mph
Dry mass of motorcycle	736 lb	736 lb.
Maximum Gross Vehicle Weight	1344lb.	1344 lb.
Noise level	below 80db	below 80db
Fuel consumption	31.3 mpg	31.3mpg

OVERALL DIMENSIONS

Length	2580 mm / 8 ft
Width	1700 mm / 5 ft 6 in
Height	1100 mm / 3 ft 6 in
Road Clearance	125 mm / 5 in
Seat height	840 mm / 33 in
Wheel base	1470 mm / 58 in

ENGINE

Type	4 stroke, overhead valves, opposed twin-cylinder
Displacement	745 cc
Cylinder bore	78 mm
Piston stroke	78 mm
Compression ratio	8.6 :1
Rated horsepower	23 KW / 45 BHp
Rated rotational speed	5600 RPM
Rated torque	52 N -M @ 3750 RPM
Lubrication system	Dual system of forced lubrication and splashing
Lubricant	SAE 20W/50

CARBURETOR

Carburetor type	32 CVK Keihin
Number of carburetors	2
Air cleaner	Paper Filter Element
Fuel	91 octane premium unleaded gasoline
PCV Valve	Internal Breather

ELECTRICAL

Ignition system	Electronic Ignition
Spark plugs	NGK BP7HS or Equivalent
Ignition timing	Automatic advance
Alternator	35 amp / 12 Volt
Battery	VARTA YB18L-A or equivalent
Headlight	Hela, 7" round sealed beam

TRANSMISSION

Clutch	Dry double-disk clutch
Gearbox	4 speed gearbox with reverse

GEAR RATIOS

I gear	3.6
II gear	2.28
III gear	1.56
IV gear	1.19
Reverse gear	4.36
Speedometer drive ratio	0.4
Final drive ratio	4.62

FLUID CAPACITIES

	Patrol, Gear Up	Tourist
Fuel tank (gasoline)	5 Gal / 19L	5 Gal / 19L
Reserve (gasoline)	.5 Gal / 2L	.5 Gal / 2L
Engine (oil)	68 Oz / 2L	68 Oz / 2L
Transmission (oil)	34 Oz / 1 L	34 Oz / 1 L
Final drive (gear oil)	4.5 Oz / 105 ml	3.5 Oz / 135 ml
Shock Absorbers (shock oil)	105 ml / 3.5 oz	105 ml / 3.5 oz
Brake Reservoir	DOT 3 or 4 brake fluid to upper line	

RUNNING GEAR

Frame	Tubular welded
Rear wheel suspension	Swing arms with spring shock absorbers
Front fork	Leading link
Sidecar	Cushioned body (on rubber cushions) and wheel with hydraulic spring shock absorber
Sidecar drive (Patrol and Gear Up only)	Steel shaft driven by final drive. User selectable for engagement.
Brakes	Disc-type with hydraulic drive on front, Shoe type with mechanical drive on rear and sidecar wheels
Tires	4" x 19" Front 22 psi cold (1.5 Bar / 150 kPa) Front 22 psi cold Side 22 psi cold (1.5 Bar / 150 kPa) Side 22 psi cold Rear 36 psi cold (2.5 Bar / 250 kPa) Rear 36 psi cold

CLEARANCES

	mm	in
Valves with engine cold	0.05 to 0.1	0.002 to 0.004
Between spark plug electrodes	1.016	0.040
Backlash between tooth faces of bevel gears in final drive	0.1 - 0.3	0.004

FREE TRAVEL / ADJUSTMENTS

	mm	in
Hand brake control lever	5 - 8	0.2 - 0.3
Clutch control lever	5 - 8	0.2 - 0.3
Foot brake drive pedal	¼ of full stroke of pedal, 25 - 30	1.0 - 1.2
Toe-in distance	10 mm	3/8 inch
Lean-out	1° away from sidecar	

This page left intentionally blank

TORQUE SPECIFICATIONS

Metric	US Equivalent	Location on Bike
54 to 61 Nm	40 ft/lb to 45 ft/lb	cylinder heads
237 to 251 Nm	175 ft/lb to 185 ft/lb	fly wheel tightening screws
19 to 30 Nm top	14 ft/lb to 22 ft/lb	shock absorber
38 to 49 Nm bottom	28 ft/lb to 36 ft/lb	shock absorber
30 to 35 Nm	22 ft/lb to 26 ft/lb	bearing nut
30 to 35 Nm	22 ft/lb to 26 ft/lb	final drive to swing arm bolts
16 to 19 Nm	12 ft/lb to 14 ft/lb	oil pump bolt
6.7 to 11 Nm	5 ft/lb to 8 ft/lb	engine sump
14 to 19 Nm	10 ft/lb to 14 ft/lb	final drive case nuts
25 to 30 Nm	18 ft/lb to 22 ft/lb	nut fastening the pinion bearing <i>(Patrol, Gear Up rear axle only)</i>
68 to 90 Nm	50 ft/lb to 66 ft/lb	nut fastening the pinion bearing
22 to 27 Nm	16 ft/lb to 20 ft/lb	reverse gear lever nut
19 to 22 Nm	14 ft/lb to 16 ft/lb	alternator gear nut
136 to 163 Nm	100 ft/lb to 120 ft/lb	steering stem nut

This page left intentionally blank

Chapter 2

MOTORCYCLE CONTROLS & INSTRUMENTATION

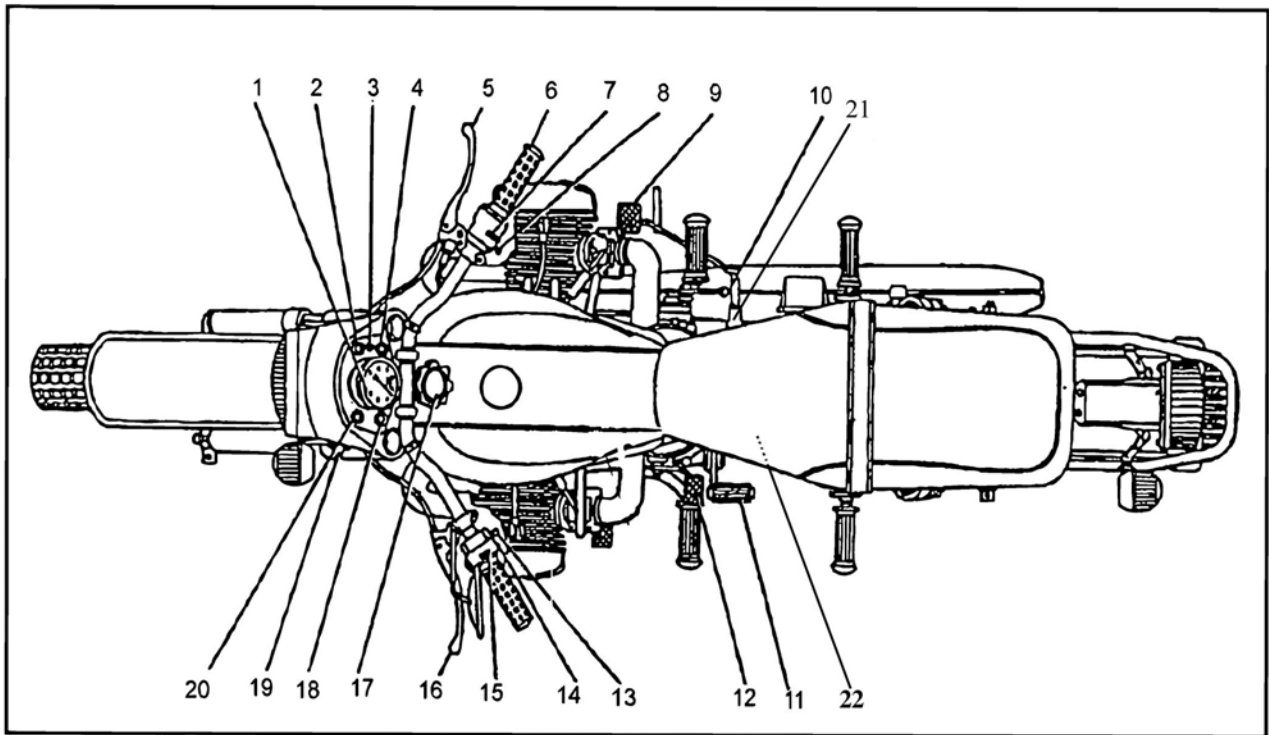

Figure 1. Controls and Instrumentation

- | | |
|--|--------------------------------------|
| 1 - Speedometer | 12 - Gear shift (foot) pedal |
| 2 - Turn indicator lamp | 13 - Turn signal switch |
| 3 - Trip odometer reset knob | 14 - Horn push-button |
| 4 - Neutral and reverse gear engagement indicator lamp | 15 - "High-low" beam switch |
| 5 - Front brake control lever | 16 - Clutch control lever |
| 6 - Throttle control twist grip | 17 - Steering damper tightening bolt |
| 7 - Ignition cutoff switch | 18 - High-beam indicator lamp |
| 8 - Electric Start Button | 19 - Ignition Switch |
| 9 - Rear brake pedal & sidecar wheel brake | 20 - Battery discharge warning lamp |
| 10 - Reverse gear lever | 21 - Parking brake |
| 11 - Kick start lever | |



Clutch Control Lever

Font Brake Control Lever

Clutch control lever . When the clutch lever is squeezed, the engine is disengaged from the gearbox. When the lever is released, the engine and gearbox are engaged.

WARNING: *MAKE SURE FINGERS ARE NOT POSITIONED BETWEEN HAND CONTROL LEVERS AND HANDLEBAR GRIPS OR OPERATION OF VEHICLE COULD BE IMPAIRED.*

WARNING: *BEFORE STARTING ENGINE, ALWAYS SHIFT TRANSMISSION TO NEUTRAL TO PREVENT ACCIDENTAL MOVEMENT WHICH COULD CAUSE POSSIBLE DAMAGE TO MOTORCYCLE AND PERSONAL INJURY.*

Caution: *Always engage the clutch release lever when shifting. Serious internal damage may result to the transmission if the clutch release lever is not engaged.*

Front brake control lever When the lever is squeezed, the front wheel brake is actuated. The front brake should be used together with rear brake.

When the brake lever is squeezed, the stop signal lights are switched on.



Gear Shift Foot Pedal

Kick Lever

Kick lever Is designed to start the engine. On pressing the lever the crankshaft of the engine is actuated through the gearbox. The lever is returned to its initial position by the spring inside the gearbox.

Gear shift foot pedal Is a two-arm type. When the front arm is depressed, shifting from higher to lower gear takes place. When the rear arm is depressed, shifting from lower to higher gear takes place. Since the heel-toe shift lever is short-coupled, you will find it easier to shift into a higher gear if you do not use your heel to shift, rather the ball of your foot. The neutral position is fixed between the 1st and 2nd gears. It is important to shift smoothly with a constant force and not to kick the gear shift pedal. Serious damage may result to the shifting mechanism if the gear shift pedal is kicked, rather than pushed.

IMPORTANT! The green pilot lamp will illuminate when either the transmission is in neutral or when the reverse gear is engaged (see “Starting the Engine”).

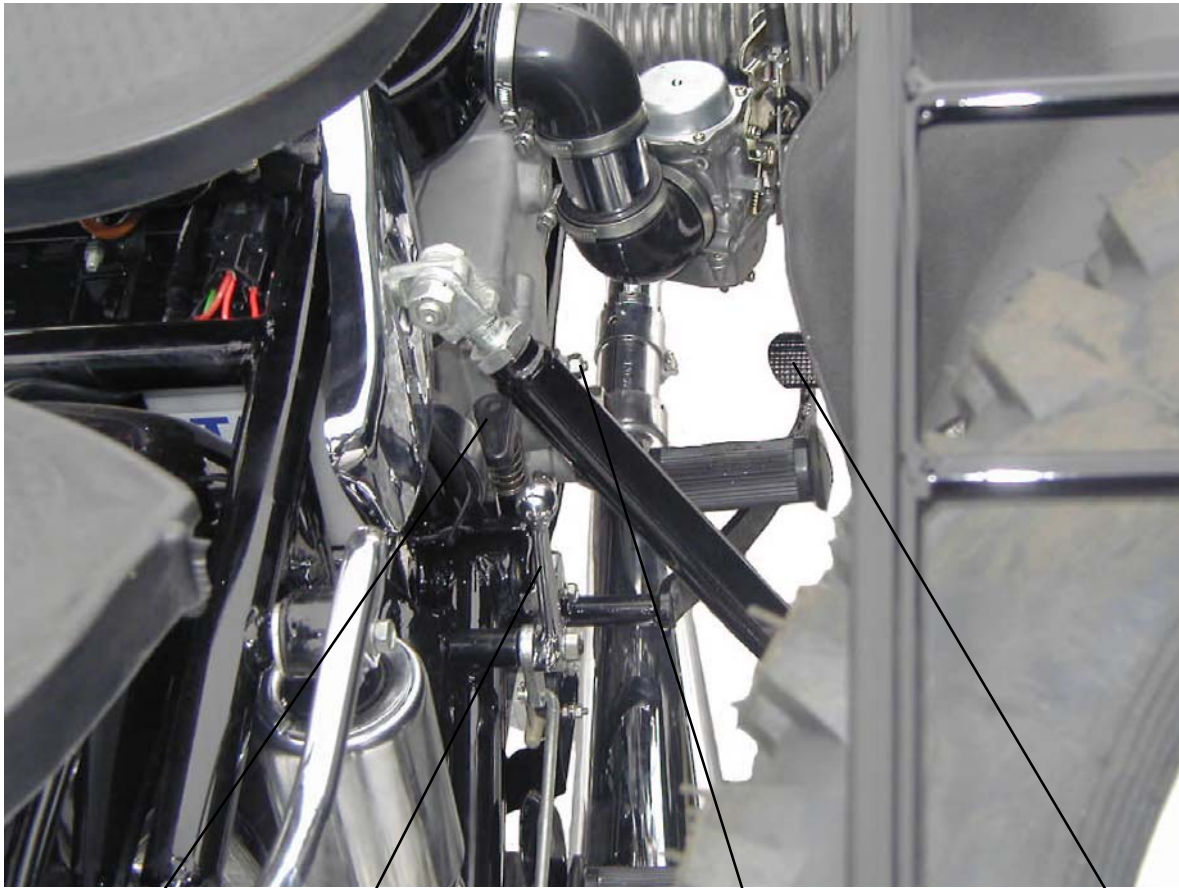

Parking Brake Sidecar Drive Lever Reverse Gear Lever Rear Brake Pedal

Parking Brake is used to hold the bike when parked. To engage, depress the rear brake pedal and push down then twist the parking brake lever counter clockwise.

Sidecar drive engagement lever is used to engage the drive axle to the sidecar wheel on the Patrol and Gear Up model motorcycles.

WARNING: *Never engage sidecar drive on concrete or hard surface. Severe damage to drivetrain will result if the sidecar drive is engaged on pavement.*

Reverse gear lever is used to move the motorcycle in reverse. The transmission must be in neutral or 1st gear for reverse gear to be engaged.

Rear brake lever is used to actuate the rear brakes.

WARNING: *DO NOT APPLY EITHER BRAKE STRONGLY ENOUGH TO LOCK THE WHEELS BECAUSE THIS MAY CAUSE POSSIBLE LOSS OF CONTROL OF THE MOTORCYCLE. ALWAYS USE BOTH BRAKES. NEVER STOP WITH FRONT OR REAR BRAKE ONLY.*

WARNING: *AN IMPROPERLY ADJUSTED REAR BRAKE PEDAL COULD INTERFERE WITH PROPER REAR BRAKE OPERATION RESULTING IN POOR BRAKE ACTION.*



Ignition Switch has three fixed positions of the key. The position and switching diagram of the ignition locks are shown above.

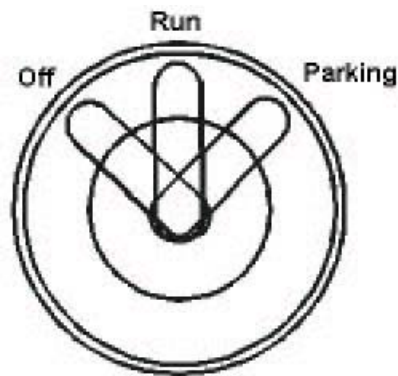

Off	All electrical systems are off.
Run	Voltage is supplied to all electrical systems.
Parking	Voltage is supplied to running lights only.

Note: Leaving the key in the Run or Parking position will discharge the battery. Always return the key to the Off position before removing it.

The indicator lamps are mounted on the instrument board:



Turn indicator pilot lamp indicates that the turn signals are activated.

Alternator fault indicator lamp, indicates that the charging system is malfunctioning and needs immediate attention.

Gearbox neutral and reverse gear engagement, indicates that the gearbox is either in neutral or in reverse.

Head lamp high beam indicator, indicates that the headlight high beam is activated.

Speedometer is on the dash board, with trip and total odometer. The trip odometer is reset to zero by rotating knob (Fig.1, # 3) counterclockwise. Note that the odometer reads in **kilometers** not miles.



Electric Start Button

Ignition Cutoff Switch



Low and High Beam Light Switch

Turn Indicator Switch

Horn Push Button

Throttle Control is on the right handlebar. Turning the twist grip increases engine speed.

Ignition Cutoff Switch has two positions, ignition off (up), and ignition on (down).

Electric Start Button is located on the right-hand twist grip, below the kill switch.

Low and High Beam Light Switch has two positions, high beam (up), and low beam (down).

Turn indicator switch is used for signaling a turn

Horn push-button is used to activate the horn

Steering Damper absorbs lateral kicks to the front wheel. Turning tightening bolt (clockwise increases friction. This can be used while riding over bad roads.



STEERING DAMPER ADJUSTMENT KNOB

WARNING: *Do NOT TIGHTEN THE DAMPER TO THE POINT WHERE THE STEERING BECOMES STIFF. DOING SO WILL ADVERSELY AFFECT HANDLING QUALITIES AND MAY DAMAGE THE STEERING MECHANISM.*

Parking brake is located on the right side of the motorcycle next to the foot peg. It is engaged by applying the foot brake pedal fully and turning the handle and pushing it down to hold the foot brake lever in the applied position.

Always disengage the parking brake before moving the motorcycle.

CONTROL CABLE ADJUSTMENT

The control cables are adjusted by screw adjustments at the cable ends.

With the control levers released:

- for the clutch a play at the clutch lever end should be equal to 5 - 8 mm/0.2 - 0.3 in.
- The rear brake pedal equal to about 25 - 30 mm/1 - 1.2 in. of the full stroke of the pedal is required
- for the carburetors - carburetor throttle cables synchronized

With the control levers (handles) fully depressed:

- for the clutch — complete disengagement of the engine from the transmission; noiseless shifting of gears means correct adjustment of the clutch cable.
- for the carburetors — lift of throttles to maximum and equal height

CONTROL CABLE MAINTENANCE

The daily preventative maintenance involves checking the functioning, condition and fastening of the tie rods, cables and braking action. Refer to the Service Coupons for lubrication schedule.

As per the service coupons;

- check the condition of the brakes
- clean the brake shoes and the active surface of the brake drums
- lubricate the hinge pins and the cams of the brake linings, the joints, the linkage of the rear and sidecar wheel brakes, the lever axle, the parking brake, the throttle control twist grip, the lever pins and ends of cables used in the clutch, the front brake control, the control cables used in the clutch, the front brake and the throttles.

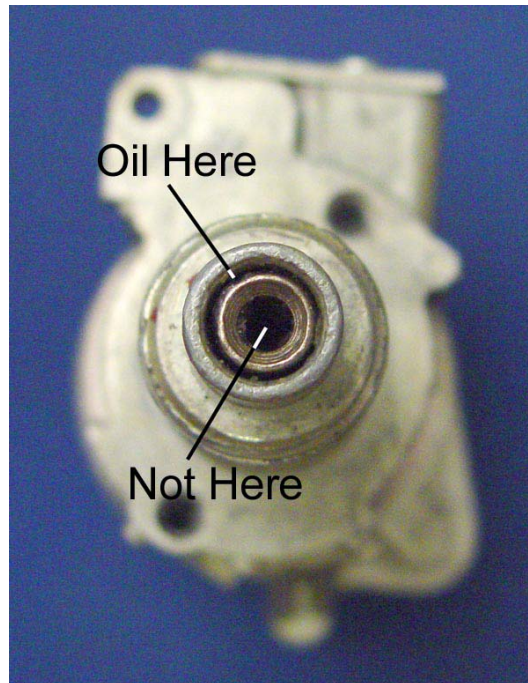

SPEEDOMETER MAINTENANCE

After every 10,000 km, remove the speedometer from the motorcycle and add five or six drops of oil into the speedometer where the cable inserts into the speedometer. This will lubricate the speedometer internally.

To lubricate the speedometer cable, remove the cable from the speedometer and extend it in a straight line. Apply speedometer lubricating oil or light machine oil at one end and allow it to seep through the length of the cable.

Chapter 3

ENGINE OPERATION

PRE-TRIP PRELIMINARIES

Pre-Trip Check List

1. Check all lights and the horn for proper operation.
2. Check the brake and clutch levers and/or pedals.
3. Make sure all wheels and the final drive assemblies are securely fastened .
4. Check the carburetor flanges and air filter ducts for integrity and proper alignment.
5. Check the tire tread depth - should be greater than 1/8 inch.
6. Check the sidecar attachment mounts – all mounts should be securely tightened.

Gasoline level in the fully filled tank should be 10 - 15 mm / $\frac{1}{2}$ - $\frac{3}{4}$ in. below the lower edge of the tank filler. Do not overfill the tank.

See that the oil level in the engine crankcase is not higher than the top and not lower than the bottom marks on the dipstick with the filler plug undone. (See chapter 4 Lubrication System)

CAUTION: When checking the engine oil level, be careful that dirt and debris do not contaminate the oil.

STARTING THE ENGINE

WARNING: BEFORE STARTING THE ENGINE, MAKE SURE THAT THE GEAR SHIFT MECHANISM IS IN THE NEUTRAL POSITION (BETWEEN 1ST AND 2ND GEARS) TO PREVENT ACCIDENTAL MOVEMENT WHICH COULD CAUSE POSSIBLE DAMAGE TO MOTORCYCLE AND PERSONAL INJURY. (FOR MORE THAN JUST STARTING, I.E. IDLING, IT IS ADVISABLE TO USE NEUTRAL GEAR.)

When the ignition is switched on, the green & red lamps on the instrument board should illuminate. Make sure that the reverse gear engagement (lever) is set to the front position. This is important since the green lamp will also be illuminated if the motorcycle is in reverse gear. Moving the reverse gear lever forward will put the gearbox in neutral.

AUTOMATIC PETCOCK

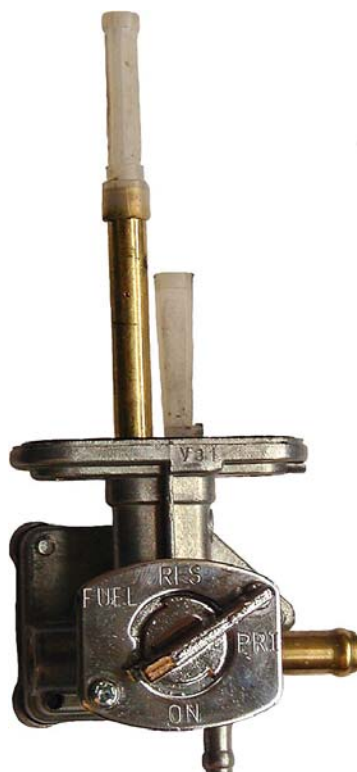

1. When starting the engine after the motorcycle has been parked for an extended period of time, or after the fuel tank and/or carburetors have been completely emptied of gasoline (e.g. due to running out of fuel, evaporation, or installation of replacement parts), set the valve to the “PRI” position. This will allow gasoline to fill the float chambers of the carburetors and prepare the engine for starting.
2. Start the engine
3. After the engine starts, set the valve to the “ON” position and keep the valve in this position for regular use of the motorcycle. (When set to “ON”, the valve is automatically activated when the engine starts and stops, opening and shutting off the supply of fuel to the carburetors)
4. After using up the main volume of fuel (engines starts stalling due to lack of fuel), set the valve to the “RES” position and continue driving. After refueling, remember to set the valve back to “ON” to avoid running out of fuel completely.

IMPORTANT: *When parking the motorcycle for extended periods of time, the valve should remain in the “ON” position.*

WARNING: *Never leave the motorcycle with the engine turned off and the valve set to “PRI” as this may result in a serious damage to the engine and will void your warranty.*



Enrichener off



Enrichener on

The carburetor enricheners provide extra fuel to the mixture. This extra fuel will allow a cold engine to start and run until it has warmed up sufficiently to allow normal operation. Use caution when using the enricheners, as they can easily cause the engine to flood, or foul the spark plugs. The enricheners should only be left on as long as necessary to keep the engine running while cold and should be turned off as soon as possible.

Depending on the engine and ambient temperature, use the carburetor enrichers and starting procedure as follows:

Manual Starting (without electric starter)

1. Turn on the ignition and depress the kick lever (see Fig. 1) about 1/4 of its travel (enough to firmly get the ball of your foot on the lever) with either your left foot or right foot, depending on what position is most comfortable with your right hand on the throttle. Take up the slack in the throttle until you can feel some slight resistance from the return springs in the carburetors, without any advance on the throttle, since this may flood the engine.
2. Give the kick lever a swift kick. When the engine starts, blip the throttle (quickly increase and decrease it) to keep the engine running, but not too fast. If the engine doesn't start, repeat the kicking procedure. A properly adjusted warm engine should start within a few kicks. If the engine doesn't start, try the procedure described below in item
3. If it still doesn't start or fire, it may be flooded.

Note: Do not completely open the throttle while kicking the engine over since it may flood the engine and the spark plugs may become fouled with gasoline.

Electric Starting

1. Set carburetor enrichers as with kick starting. Unlike manual starting, however, the gearbox does not have to be in neutral as the electric starter may be engaged with the clutch lever pulled in, or with the gearbox in neutral. Make sure the Ignition Cutoff Switch is set to "Ignition On" and push the starter button to turn over the engine.
2. When the engine has been standing for several hours but the ambient temperature is high (60°F/15°C degrees or above), try starting it without any enrichers. If it doesn't fire, then use the procedure described below.
3. When the engine is cool or cold and the ambient temperature is between 40°F-60°F/5°C-15°C, depress both enrichers to start. As soon as the engine starts, immediately retract the enrichers. Run the engine at moderate speed for 30-60 seconds. If it starts to die, blip the twist grip throttle (rapidly twist part way towards full throttle and then back off) to keep the engine running. After 1 to 3 minutes, depending on ambient temperature, the engine should run smoothly without "blipping" the throttle.
4. If the engine is cold and ambient temperature is below 40°F, first, give the engine 5-10 (depending on how cold it is) priming kicks with the ignition off. This will get some oil circulated to key internal parts. Engage the enrichers on both carburetors. The engine should then fire, depending on how cold it is. For example, when the ambient temperature is 0°F, it

typically takes about 5-10 rotations to start the engine. As soon as the engine starts, retract both enricheners (after a few seconds).

Note: It is very important to back off on the enricheners as soon as the engine will sustain itself without stalling. Since the Ural is a carbureted air cooled engine, the plugs will foul quickly (as soon as one minute) if the engine mixture is too rich. If one plug fouls and the other doesn't, the engine will run unevenly and may cause internal damage.

When the engine is hot, do not choke or enrichen the carburetors. To do so risks flooding the engine.

To start an engine that is flooded, first open the throttle fully, hold it there and give the engine up to 10 swift kicks. If it still doesn't fire, take the spark plugs out to see if they are wet with gasoline. If they are wet, dry them. Clear excess gasoline from the cylinders by kicking the engine over 10 times with the plugs out and the throttle closed. Then replace the plugs and repeat the starting procedure described at the beginning of this section (1).

WARNING: SUSTAINED OPERATION ON ONLY ONE CYLINDER FOR EVEN JUST A FEW MINUTES COULD OVERHEAT THE CYLINDER AND CAUSE IRREVERSIBLE DAMAGE TO EITHER THE VALVES OR PISTON. **T**HUS IT IS CRITICAL TO IMMEDIATELY SHUT THE ENGINE DOWN IF IT APPEARS TO BE RUNNING ON ONLY ONE CYLINDER.

Additional Warnings: Once the engine starts, do not allow it to run at a high speed as this could cause abnormal wear of the parts and may lead to seizure of the piston pin and pistons in the cylinders since cold oil flows through the oil ducts with difficulty and fails to ensure sufficient lubrication.

A correctly adjusted warm engine should run steadily at low speed with the throttle control twist grip fully closed.

Do not let the motorcycle sit at idle for more than three minutes, as overheating could result.

OPERATING PRECAUTIONS

WARNING: MAKE SURE THAT SIDECAR WINDSHIELD IS IN THE FULL BACK POSITION SO IT DOESN'T INTERFERE WITH THE RIGHT HANDLEBAR.

To move the motorcycle from rest, shift to 1st gear only. Avoid releasing the clutch suddenly, because the engine is liable to stall or the motorcycle will start with a jerk. Do not drive the motorcycle at speeds below the recommended speeds with the 2nd, 3rd or 4th gears engaged. It is not advisable to use the 1st and 2nd gears for a long time, unless so required by road conditions.

WARNING: *SHIFTING TO LOWER GEARS WHEN SPEED IS TOO HIGH MAY SEVERELY DAMAGE THE TRANSMISSION OR CAUSE THE REAR WHEEL TO LOSE TRACTION.*

CAUTION: *Do not run the engine at extremely high rpms with clutch disengaged or transmission in neutral. Do not idle the engine unnecessarily for more than a few minutes with the motorcycle standing still.*

When operating the Ural motorcycle on the highway, please try not to run continuously at speeds above 65mph. If it is necessary to drive at speeds of 65mph and above, let the engine cool by running at a reduced speed for 10 - 15 minutes every 30 minutes if possible. This will provide longer engine life.

WARNING: *WHEN RIDING ON WET ROADS OR UNDER RAINY CONDITIONS, BRAKING EFFICIENCY IS GREATLY REDUCED AND CAUTION SHOULD BE USED WHEN APPLYING THE BRAKES, ACCELERATING OR TURNING. THIS IS ESPECIALLY TRUE IMMEDIATELY AFTER THE RAIN BEGINS AND THE OIL FROM THE ROAD SURFACE COMBINES WITH THE WATER.*

When descending a long, steep grade, downshift and use engine compression together with intermittent application of both brakes to slow the motorcycle. Avoid continuous use of brakes to reduce overheating of the brakes and reduced efficiency.

While using the motorcycle in summer, pay special attention to the condition of the tires. Keep them inflated up to pressures specified in this manual.

RUNNING IN THE NEW MOTORCYCLE

The running-in period for the motorcycle is the first 1,500 km.

There are no special procedures that must be followed, but during the running-in period, a new motorcycle requires the most careful attention. In the course of this period, do not overload the machine. Avoid traveling on freeways and climbing steep hills. Do not race the engine or overheat it at any time. Vary the throttle setting frequently, so as to avoid constant RPMs. Allow the new engine frequent rest periods for cooling down.

Chapter 4

ENGINE DESIGN

The motorcycle is equipped with a two-cylinder four-stroke air-cooled engine. The opposed arrangement of cylinders in the horizontal plane is the outstanding feature of the motorcycle design which ensures proper cooling and balancing of the crank gear. The engine valves are located in the cylinder heads.

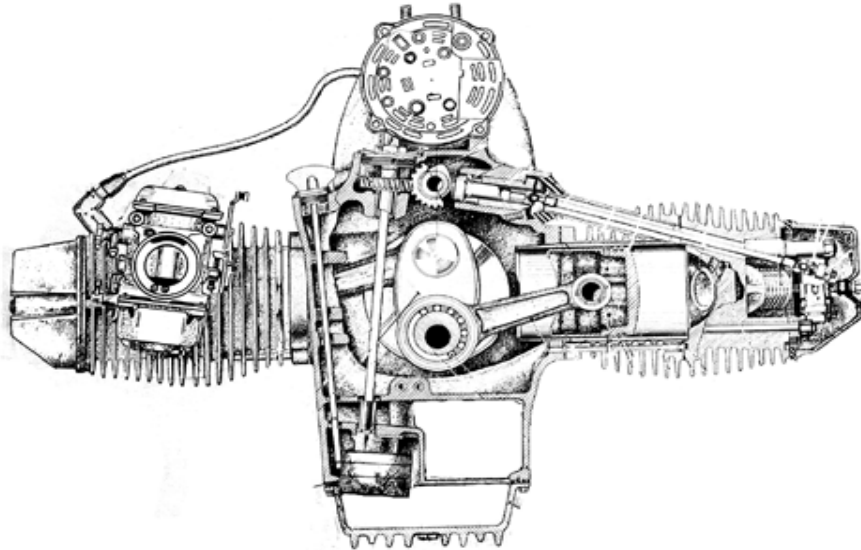

In summer, carefully observe the heating condition of the engine, power transmission units and the running gear mechanisms. Under normal heating conditions of the engine, the temperature of the cylinder heads should not be over 356°F-428°F/180°C-220°C.

During everyday preventive maintenance, clean the engine of mud and dust, paying special attention to the cooling fins as their fouling will impair the efficiency of the engine cooling. Check engine crankcase, cylinders and cylinder heads for oil and fuel leaks. Check carburetor to cylinder head compliance fittings for any cracks or leaks. Visually inspect the alternator for any oil leaks.

LUBRICATION SYSTEM

The motorcycle engine features a dual lubrication system, some parts are force-lubricated by pressure built up by the oil pump, while others by splashing . A full-flow paper oil filter is provided in the lubrication system to prolong the engine life.

Maintenance of lubrication system. During the daily inspection, check the oil level in the engine crankcase and top off the oil if necessary. Warm up the engine before changing the oil. Drain used oil from the engine and the oil filter cavity after having unscrewed the drain plug and filter plug. Change oil filter at the intervals shown in the service coupons. Set the rubber sealing bushing into the filter and fit the filter with the bushing onto the adapter of plug, then screw the latter into the front cover. Now screw in the plug. Fill the engine with 68 oz. oil, or until the top mark of the dipstick is reached.

Let the engine run for 3 - 5 min. Check the oil level again adding oil up to the top groove of the dipstick if needed. During motorcycle service, keep oil level in the engine crankcase close to the top groove of the oil dipstick. Don't ride the motorcycle if the oil level is below the lower mark of the dipstick, until sufficient oil is added to raise the oil level to the top mark.

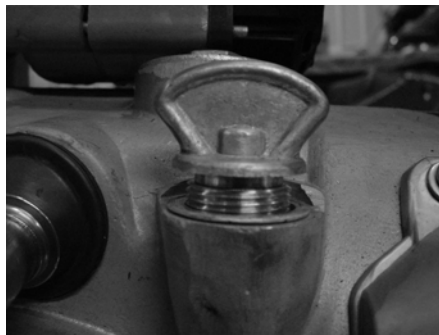

Make sure that the dipstick is screwed down securely after measuring the oil level.

FUEL SYSTEM

The fuel system includes the gasoline tank, the three-way fuel valve with filter and two carburetors.



Fuel valve (petcock). The top threaded portion of the valve is screwed into the gasoline tank. The petcock is of an automatic shutoff design. Vacuum from the engine opens the valve when the engine is running. When the engine is stopped and loses vacuum, the petcock automatically shuts off.

WARNING: *FILL FUEL TANK SLOWLY TO PREVENT FUEL SPILLAGE. DO NOT OVERFILL ABOVE THE BOTTOM OF FILLER NECK INSERT. LEAVE AIR SPACE TO ALLOW FOR FUEL EXPANSION. FUEL EXPANSION CAN CAUSE OVERFLOW THROUGH THE FILLER CAP VENT ONTO SURROUNDING AREAS. AFTER REFUELING, MAKE SURE FILLER CAP IS SECURELY TIGHTENED.*

Fuel system maintenance. Before a trip, check the tightness of gasoline piping joints, & proper functioning of throttle cables.

IGNITION SYSTEM

The ignition system incorporates the power supplies, ignition coil, Hall Effect pickup, electronic module, two spark plugs, a set of low and high voltage wires and the ignition switch.

The ignition system will provide the spark to the spark plugs from 200 to 6000 RPM. With the engine at rest, the ignition system will draw 100 mA. With the engine running, the ignition system will draw 1.5 Amps. The operating voltage for the ignition system ranges between 7 to 16 Volts. The electronic ignition system will automatically provide the required changes in timing to an accuracy of within + 1°.

Ignition coil The ignition coil has two high voltage terminals, each supplying one of the cylinder spark plugs and operating in conjunction with the Hall Effect pickup.

Periodically, check all wires in the ignition system to be sure they aren't crimped or have loose connections. Loose connections will cause erratic performance and poor fuel economy.

Spark plugs. In certain situations, spark plugs can quickly foul with carbon or soot. The plugs can be cleaned but it is easier to put in a new set of plugs when on the road. We recommend that you purchase an extra set of these plugs from your Authorized Ural Dealer and carry them in the motorcycle at all times.

WARNING: Do NOT OVERTIGHTEN THE SPARK PLUG WHEN MOUNTING IT ON THE ENGINE, SINCE THIS COULD DAMAGE THE CYLINDER HEAD.

Functioning of ignition system. Both plugs fire simultaneously on the left and right-hand cylinders, one spark being formed when the compression stroke terminates in one of the cylinders and the other during the exhaust stroke.

IGNITION TIMING

To set the ignition timing, proceed as follows:

- Match the first mark on the flywheel with the center marks on the engine flywheel window.
- Loosen the fastening screws of the microprocessor unit and turn it counterclockwise until it stops.
- Apply power to the ignition system by switching the ignition on.
- Slowly turn the ignition unit clockwise, (the LED should be on)
- Stop turning the microprocessor unit when the LED turns off.
- Tighten the fastening screws of the microprocessor unit and switch the ignition off.

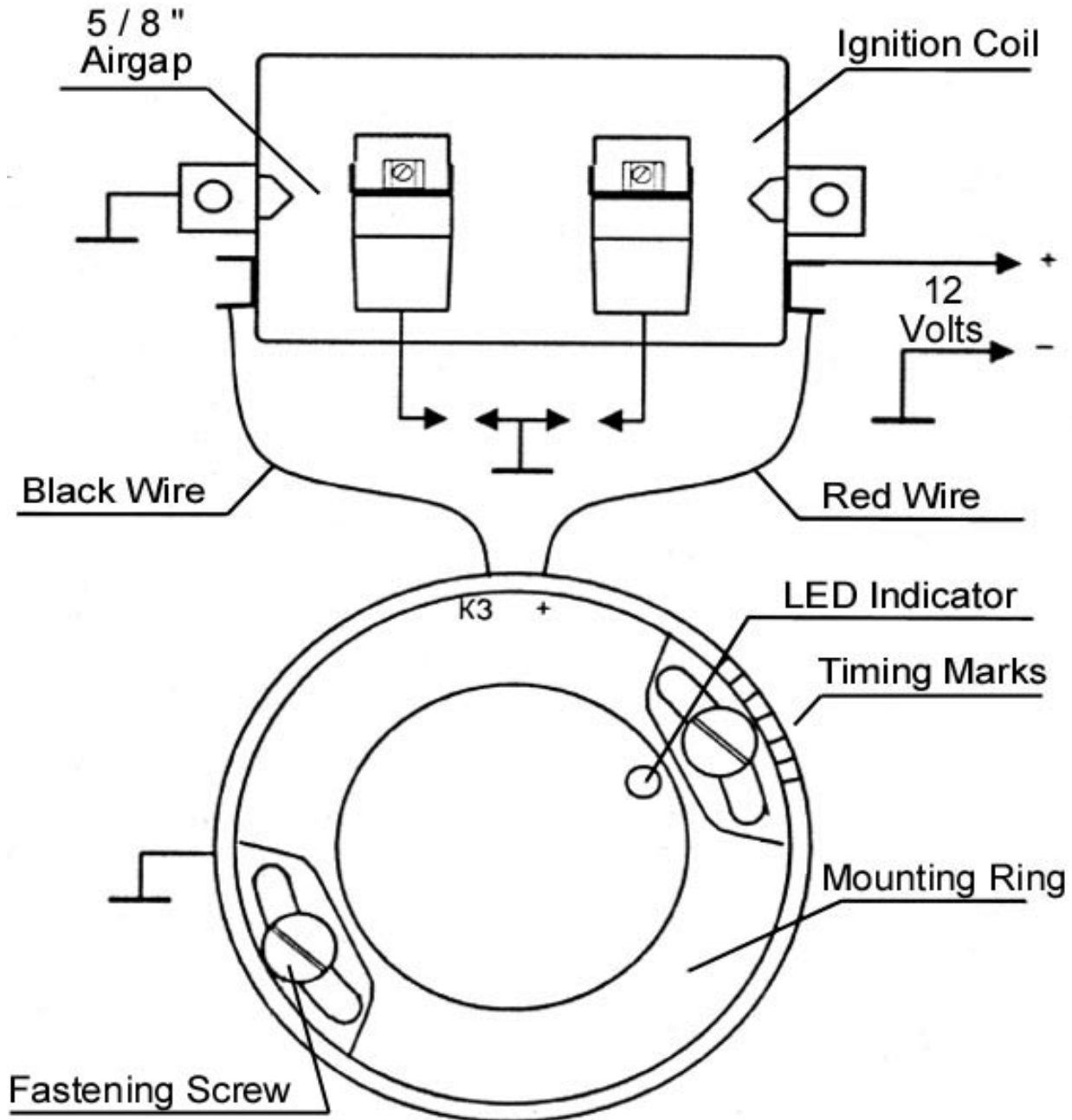

This page left intentionally blank

Chapter 5

CARBURETORS

32mm CVK Keihin Seike carburetors are used on of the Ural motorcycle. They are preset with fixed mixture jetting and adjust automatically for altitude variations. This is due to the vacuum activation mechanism of these constant velocity type carburetors. Be sure to check the condition of all carburetor adapters and air pipes every time before riding. If the carburetor flanges are in need of replacement, use only genuine Ural replacement or Ural recommended parts.

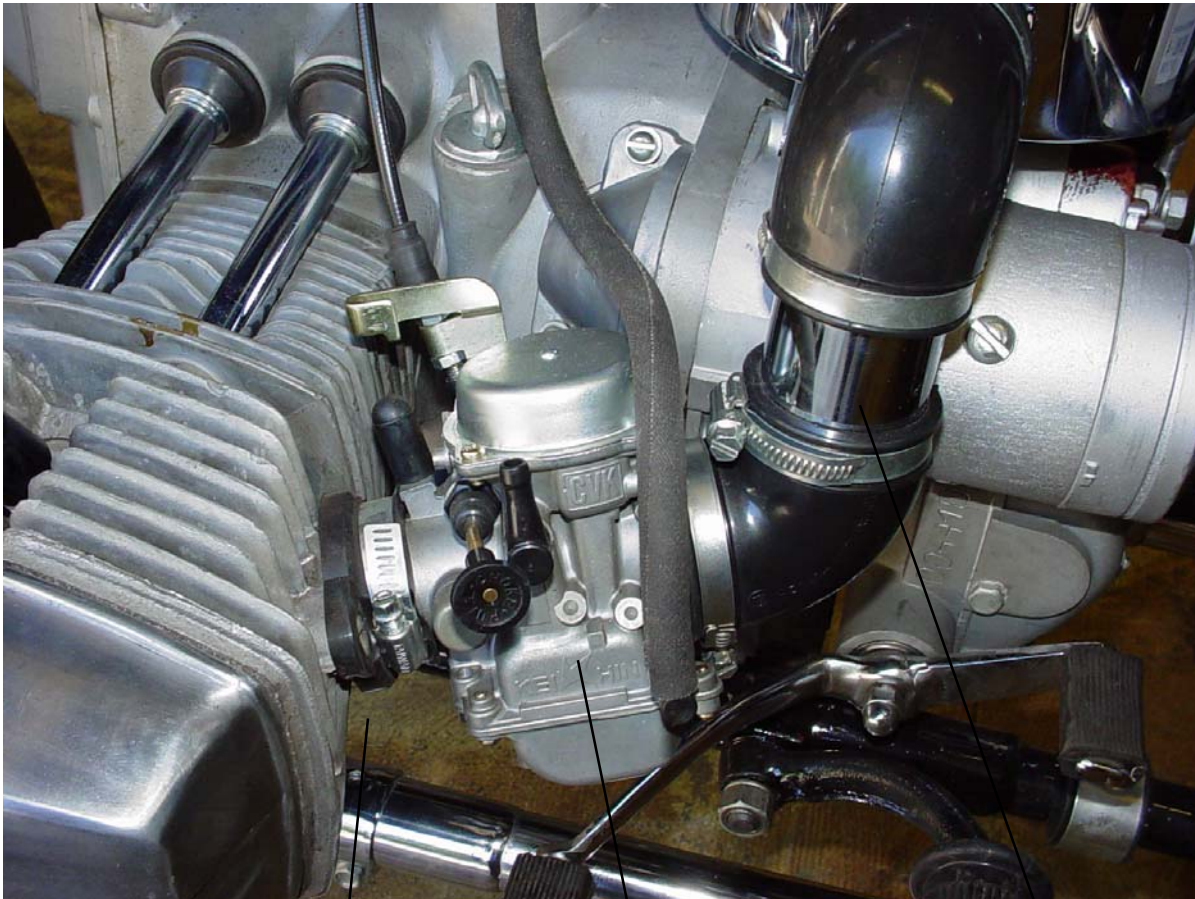

Adapter

Carburetor

Branch Pipe

WARNING: *TO AVOID SEVERE ENGINE DAMAGE, DO NOT MODIFY CARBURETOR SYNCHRONIZATION, JETS, OR THROTTLE LINKAGE. THIS AIR COOLED ENGINE MUST ALWAYS RUN ON BOTH CYLINDERS AS EVENLY AS POSSIBLE. WHENEVER ONE CYLINDER IS NOT FIRING, STOP THE ENGINE AND DETERMINE THE CAUSE AND CORRECT IT BEFORE PROCEEDING.*

WARNING: *Never use a metal adapter between the carburetor and cylinder head. This will automatically void the warranty and cause significant damage.*

CARBURETOR MAINTENANCE

The carburetors will require the fuel in the float bowls be drained periodically. This will ensure that any contaminants that have accumulated in the float bowls do not enter the main or idle jets of the carburetors. The fuel can be drained by opening the drains provided on the bottom of the float bowls.

The fuel filters should also be changed every 10,000 km or when they appear to be dirty or blocking fuel. Changing the filters will ensure that clean fuel is provided to the carburetors and that there is no fuel starvation.

The carburetor to cylinder head adapters should be checked for leaks and cracks every trip. Failure of the adapters will cause the carburetor fuel mixture to become lean and cause internal damage to the engine.

CALIFORNIA EMISSION SYSTEM

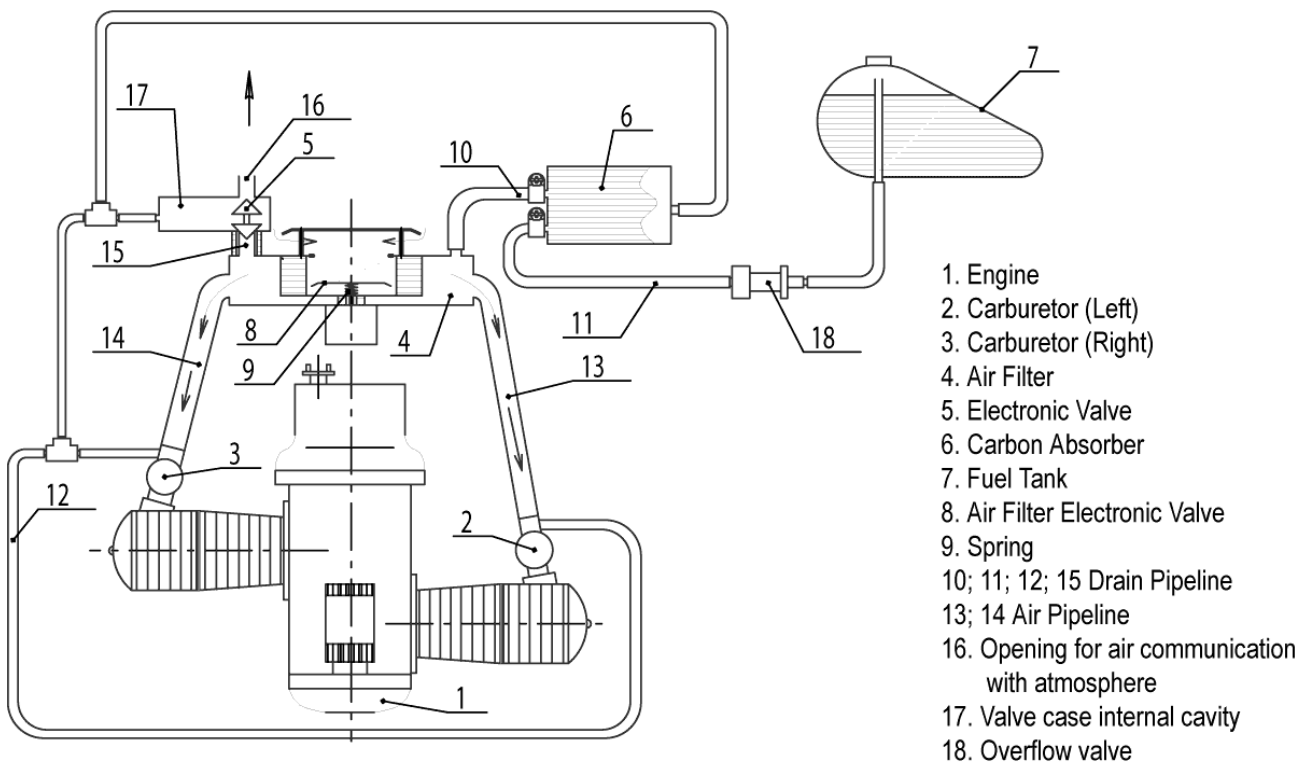

Chapter 6

POWER TRANSMISSION

The power transmission system of the motorcycle is comprised of the clutch, gearbox, and the final drive.

CLUTCH

The clutch transmits torque from the engine to the gearbox. Disengage the engine from the gearbox during shifting of the gears and when braking to a stop. The clutch provides for smooth starting of the motorcycle from rest, protects the power transmission parts against damage when the engine speed or drive wheel speed is suddenly changed. The clutch is of dry double-disk design. The clutch release mechanism is controlled by the lever on the left grip of the handle bar. With the clutch lever released, the engine is engaged to the gearbox. When the clutch lever is squeezed, the engine is disengaged from the gearbox. **Use the clutch lever for starting from rest and for gear shifting.** Under conditions of heavy traffic, when gears frequently have to be shifted, do not slip the clutch too much, as this will accelerate wear of the disks.

GEARBOX

The reverse gear should be engaged from neutral or first gear when the bike has come to a stop.

Shifting the gears is best accomplished by pushing down on the front toe plate for first gear and to downshift from higher gears. To shift up into second, third and fourth gear, use the rear toe plate and push down quickly and firmly. Since the Ural transmission is a non-synchronized design, it is very important that the clutch be used when shifting. Not using the clutch when shifting can cause damage and void the warranty.

CAUTION: *Severe damage due to insufficient lubrication of gears, shafts and bearings can result if the oil level is allowed to get lower than the specified level.*

FINAL DRIVE

Maintenance of propeller shaft splines and final drive.

Remove the final drive from the swing arm and pull the final drive towards the rear of the bike. When the drive shaft is free, coat the drive shaft splines with grease. At the same time, use a grease gun to force grease into the drive shaft universal joint.

Typical final drive maintenance includes tightening the nuts which fasten the final drive to the swinging fork arm. Failure to tighten the nuts may result in loose joints and the destruction of the final drive cover. Change the final drive oil as determined by the service coupons. Undo the filler and drain plugs and drain the used oil. Fill the casing with fresh 20w / 50 Castrol oil and flush the final drive by turning the rear wheel several times. Drain the 20w / 50 Castrol oil and then refill the final drive with the specified lubricant.



Chapter 7

RUNNING GEAR

MOTORCYCLE AND SIDECAR FRAMES

The frame is the principal bearing element of the motorcycle to which all the units and assemblies of the motorcycle are attached. The motorcycle is furnished with a twin closed frame of welded construction.

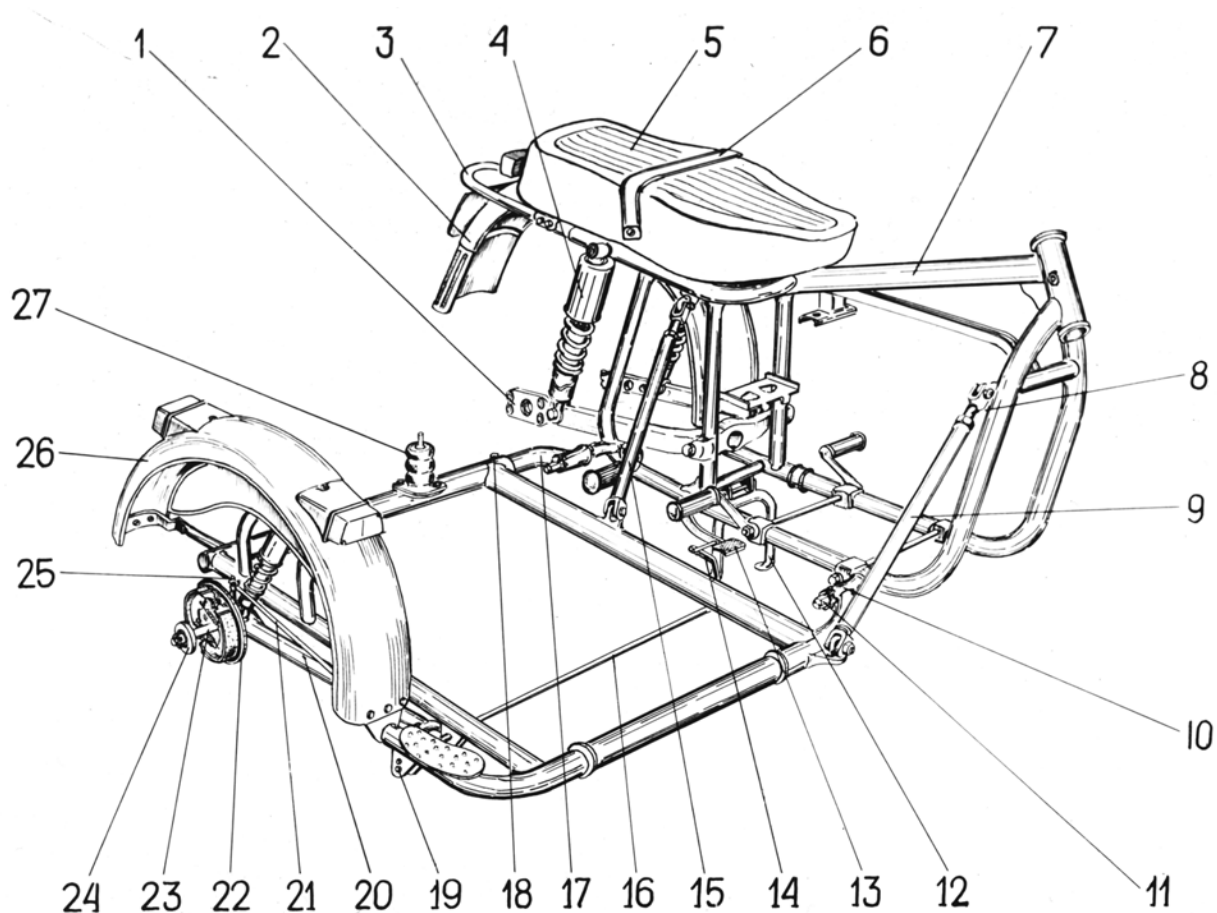

1-Rear suspension swing arm; 2-Rear fender; 3-Rear fender strap; 4-Spring and hydraulic shock absorber; 5-Saddle; 6- Saddle handle; 7- Motorcycle frame; 8- Leg adjusting fork; 9,15-Sidecar frame legs; 10- Colett clamp; 11-Collet clamp screw; 12-Motorcycle stand; 13-Foot brake pedal; 14-Sidecar brake lever; 16-Sidecar brake lever axle; 17-Rear collet bracket; 18- Rear bracket bolt; 19- Lever pins; 20- Lever; 21-Brake tie rod; 22-Brake drum cover; 23-Sidecar wheel axle; 24-Protective cap; 25-Tie rod nut; 26-Sidecar fender; 27-rubber member of body suspension.

SPRING LOADED HYDRAULIC SHOCK ABSORBER

The suspension features cam-type adjusters used for varying the preload of the supporting springs to suit the load and the road conditions. The degree of tension on the springs is adjustable allowing two positions. The first (lower) position corresponds to the load due to the motorcycle's own weight, the driver's and one passenger's (sitting in the sidecar) weight; the second (upper) position of the adjuster corresponds to the maximum load.

When the motorcycle is used under the maximum load, adjust the spring in the sidecar wheel shock absorber simultaneously while adjusting the compression of the spring in the motorcycle shock absorbers.

Care of shock absorbers. Fill the shock absorber with 105 cm³ of hydraulic fluid. Each time during maintenance, check the bolts affixing the top and bottom end of the shock absorbers for tightness.



ADJUSTMENT OF SIDECAR INSTALLATION

The sidecar should be installed in a definite position relative to the motorcycle. The position is determined by the camber and toe-in of the motorcycle and the sidecar wheels. An incorrectly aligned sidecar will drag the motorcycle to either side and cause extensive tire wear. If the motorcycle is not stable on the road or is difficult to steer, check the alignment. Checking and measuring the alignment should be done on level ground.

Check toe-in of the motorcycle and the sidecar wheels with two straight bars applied to the side faces of the wheels just below the axles. The toe-in should be 5 to 15 mm or 3/16 to 9/16 in. at the front wheel. When adjusting, unbolt the top of the slanting legs fastening the sidecar to the motorcycle, slacken off the bolt clamping the lower rear bracket, adjust the position of the bracket relative to the rear tube of the sidecar frame to obtain necessary toe-in of the wheels. Tighten up the bolt fastening the bracket, adjust the length of the legs and secure them with bolts.

Check the lean-out of the motorcycle using a level gauge or protractor with a plumb bob and a ruler. Adjust the two inclined legs by screwing the forks in or out. When the lean-out is correct, the rider will remain vertical while riding on the local roads which may be slightly sloped to assist with water runoff.

Check the toe-in while the motorcycle is running on the road. With the toe-in properly adjusted, the motorcycle will not pull to either side while running at normal road speed. If it pulls to the right, increase the toe-in, if it pulls to the left, decrease the toe-in.

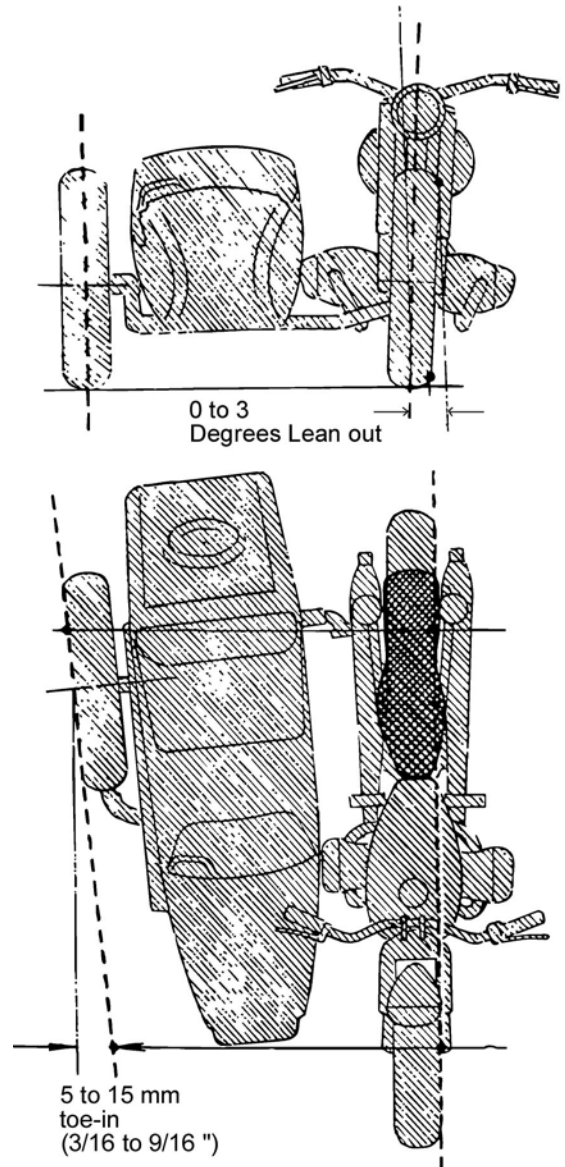

CAUTION: Double check for correct toe-in before making any change to lean-out.

FRONT FORK

The **leading link front fork** used on the Tourist and Patrol models use a front lever-type fork with two interchangeable spring-hydraulic shock absorbers.

The friction type **steering damper** is made up of two steel washers, moving and fixed, two fiber washers and tightening bolt with a head. Friction between the steel and the fiber washers makes turning of the front fork more difficult.

WARNING: Do NOT OVER TIGHTEN THE STEERING DAMPER SINCE THE MOTORCYCLE WILL BECOME VERY DIFFICULT TO HANDLE.

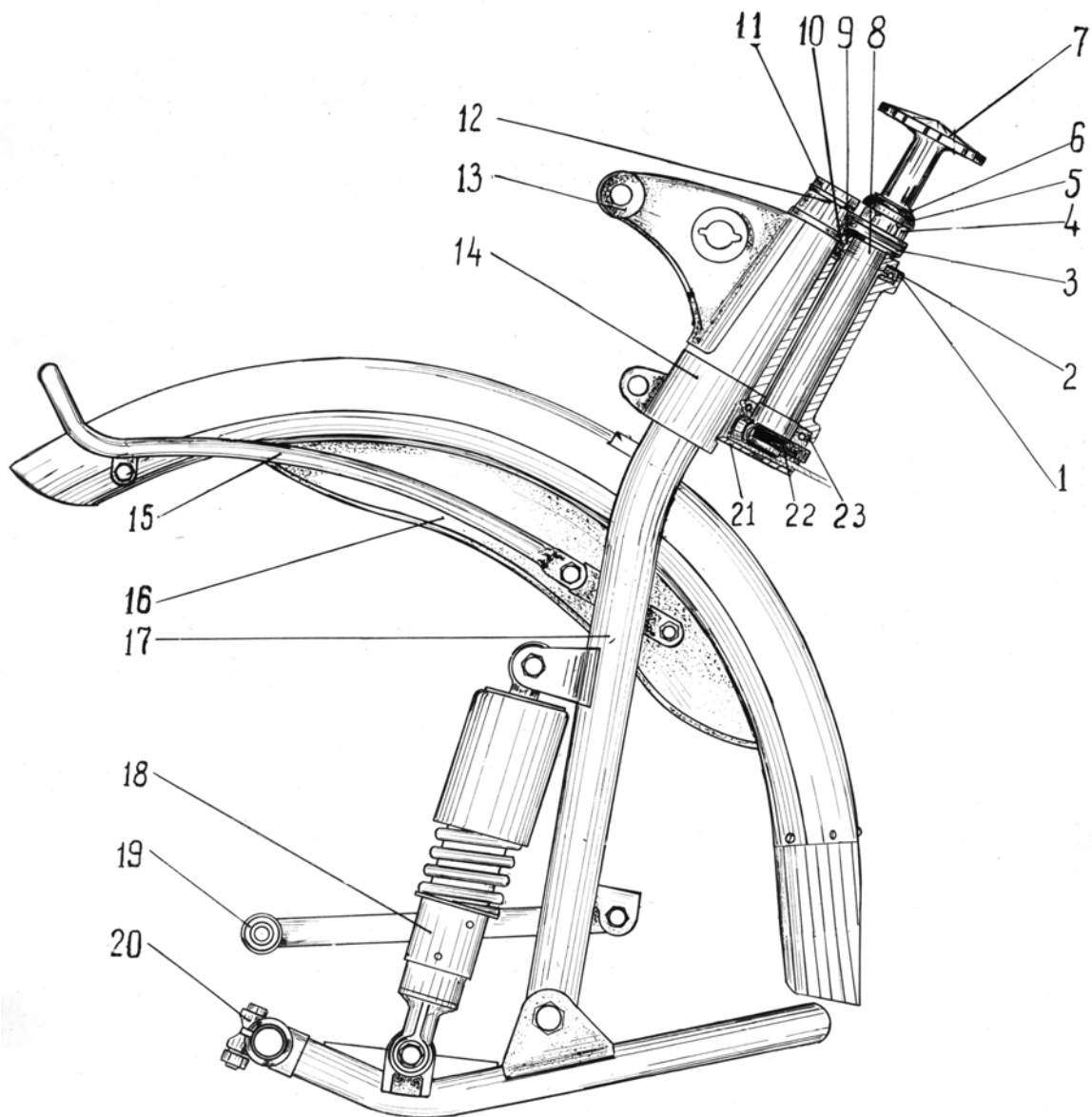

Front fork of leading link type

1-Protective washer; 2- Seal; 3-Cross-piece; 4-Steering column stem nut; 5-Thrust washer; 6-Spring washer; 7-Tightening bolt; 8-Steering column stem; 9-Bearing nut; 10- Top ball radial thrust bearing; 11-Tightening nut; 12-Washer; 13- Leg cover with headlight bracket; 14-Steering column bridge; 15-Front fender clip; 16-Front fender; 17-left fork leg tube; 18-spring and hydraulic shock absorber; 19-Brake drum cover thrust link; 20-Wheel lever; 21-Moving ring; 22-Fixed ring; 23-Lower ball radial thrust bearing;

STEERING HEAD BEARINGS

The steering head bearings must be adjusted periodically to avoid excessive play which might cause steering instability. When properly adjusted, the front fork should turn with just a hint of bearing drag, but without free play or obvious resistance to turning.

WARNING: IMPROPER ADJUSTMENT OF THE STEERING HEAD (E.G. TOO TIGHT) WILL MAKE THE MOTORCYCLE VERY DIFFICULT TO STEER. THIS ADJUSTMENT IS CRITICAL FOR PROPER HANDLING OF ALL MODELS.

Chapter 8

WHEELS AND TIRES

The Ural motorcycle is equipped with easily demountable wheels with the cast (aluminum) brake drum on short spokes of the same size on the rear wheels and steel disc and machined hub on the front wheel.

Removing wheels. To remove the front wheel, set the motorcycle on its stand, lift it by the front wheel and put a rest under the front portion of the motorcycle frame. (You may want to purchase a scissor jack or bottle jack to carry along in the sidecar storage compartment. This will make it easier to change any of the three wheels on the rig.) Slacken the nut of the union bolt at the end-piece base of the fork left-hand leg. Screw out the axle turning it clockwise (left-hand thread) and remove the wheel together with the front brake disc.

To reinstall the front wheel on the motorcycle follow the reverse order of the above operations seeing to it that the brake disc evenly engages with the brake caliper.

To remove the rear wheel of the motorcycle, lift the motorcycle onto the center stand. Undo the rear wheel axle nut and take it off together with the washer, slacken off the nut on the union bolt of the left-hand leg of the swinging arm, pull out the rear wheel axle with the help of a wrench bar and remove the wheel.

To reinstall the wheel on the motorcycle follow the reverse order of operations. Prior to reassembling, wipe the axle and grease it. Fitting the rear axle, turn it as you push it in to avoid jamming.

To remove the spare wheel, use the wrench from the tool kit that has two studs that fit the two holes in the round nut holding the luggage rack down.

Care should be taken to keep tires properly inflated. Check before riding when tires are cold. Do not overinflate tires.

Warning: *Never interchange the front for the rear wheels.*

WARNING: *IMPROPER TIRE INFLATION WILL CAUSE ABNORMAL TREAD WEAR AND COULD RESULT IN UNSTABLE HANDLING. UNDER-INFLATION COULD RESULT IN THE TIRE SLIPPING ON THE RIM.*

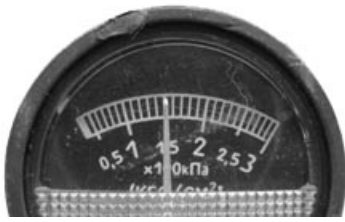

1.5 Bar

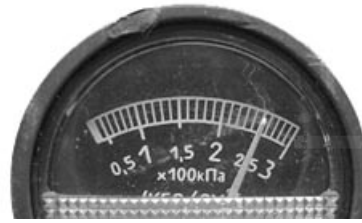

2.5 Bar



**or 150 kPa
Front & Sidecar
tire pressure**



**or 250 kPa
Rear
tire pressure**

Check inflation pressure and inspect tread for punctures, cuts, breaks, etc., at least weekly if in daily use or before each trip, if used occasionally.

WARNING: *RIDING WITH EXCESSIVELY WORN, UNBALANCED OR IMPROPERLY INFLATED TIRES IS HAZARDOUS AND WILL ADVERSELY AFFECT TRACTION, STEERING AND HANDLING. SAME AS ORIGINAL EQUIPMENT TIRES MUST BE USED. OTHER TIRES MAY NOT FIT CORRECTLY AND MAY BE HAZARDOUS TO USE.*

BECAUSE TIRES, TUBES AND WHEELS ARE CRITICAL SAFETY ITEMS AND SERVICING OF THESE ITEMS REQUIRES SPECIAL TOOLS AND SKILLS, WE RECOMMEND YOU SEE YOUR IMWA DEALER FOR THESE SERVICES.

TIRE DATA

WARNING: *FOR YOUR OWN PERSONAL SAFETY, TIRES AND TUBES MUST BE CORRECTLY MATCHED TO WHEEL RIMS. SEE YOUR AUTHORIZED IMWA DEALER FOR FURTHER INFORMATION. MISMATCHING TIRES, TUBES AND RIMS MAY RESULT IN DAMAGE TO THE TIRE BEAD DURING MOUNTING OR MAY ALLOW THE TIRE TO SLIP ON THE RIM, POSSIBLE CAUSING TIRE FAILURE. IN ADDITION, USING TIRES OTHER THAN THOSE SPECIFIED MAY ADVERSELY AFFECT MOTORCYCLE STABILITY. PROTECTIVE RUBBER RIM STRIPS MUST BE USED. TIRE SIZES ARE MOLDED ON THE TIRE SIDEWALL. TUBE SIZES ARE PRINTED ON THE TUBE.*

Ural tires that have been tested by the manufacturer to ensure compliance with DOT requirements are available from your Authorized IMWA Dealer.

The following tire data labels are mounted on the front frame of your Ural.

For motorcycle with sidecar , 19" tire

Front: 491 lb. (223 kg) with 4.00 x 19 tire, 19 x 3.00 rim, at 22 psi cold (1.5 Bar)

Side: 304 lb. (138 kg) with 4.00 x 19 tire, 19 x 3.00 rim, at 22 psi cold (1.5 Bar)

Rear: 577 lb. (262 kg) with 4.00 x 19 tire, 19 x 3.00 rim, at 36 psi cold (2.5 Bar)

WARNING: *MAXIMUM INFLATION PRESSURE MUST NOT EXCEED SPECIFICATION ON TIRE SIDEWALL.*

WARNING: *WHEN TIRES ARE WORN TO A TIRE CENTER TREAD DEPTHS OF 3/32 IN, THEY SHOULD BE REPLACED.*

WHEEL AND TIRE MAINTENANCE

During the pre-trip inspection, check air pressure in the tires (chapter 1).

Check axle and spokes for safe fastening, be sure to tighten the spokes or fasteners and eliminate play as soon as they get loose or demonstrate excessive play.

While lubricating, consult the Lubrication Chart in chapter 11.

WARNING: *WHEEL TRUING INVOLVING MORE THAN 2 TURNS OF ANY SPOKE NIPPLE SHOULD BE ACCOMPLISHED WITH THE TIRE DISMANTLED SO THAT SPOKE ENDS CAN BE CHECKED TO ENSURE NO SPOKES PROTRUDE INTO THE INNER TUBE.*

Wheel Construction

Two adjustable tapered roller bearings are pressed into the wheel hub, which are prelubricated with LITOL-24 type grease. Depending on motorcycle versions, the wheels with aluminum cast brake drum or disc type may be used. The adjustment of bearings is the same for both styles of wheel.

Adjustment of wheel bearings.

The wheel bearing life is greatly extended through proper adjustment. Check the condition of bearings and adjust tightening of them every 5000 km. To adjust the bearings proceed as follows:

- Remove the wheel from the motorcycle;
- Fit the rear wheel axle (without protective cap), tighten it by nut with the aid of a bushing, 100 mm long, with 21 mm ID and 25...30 mm OD, or a set of bushing of given size.
- Determine if there is a play by turning the axle (but not the wheel on the axle) and rocking it, slacken off the lock nut.
- Screw the seal nut up to the limit, then release it by $1/6..1/8$ of the turn so that the axle-bushing system rotates without play, easily and without jamming. The overtightening of bearings is strictly prohibited.
- Tighten the lock nut without effecting the bearing adjustment.
- Pull the axle out.
- Put the wheel onto the motorcycle.

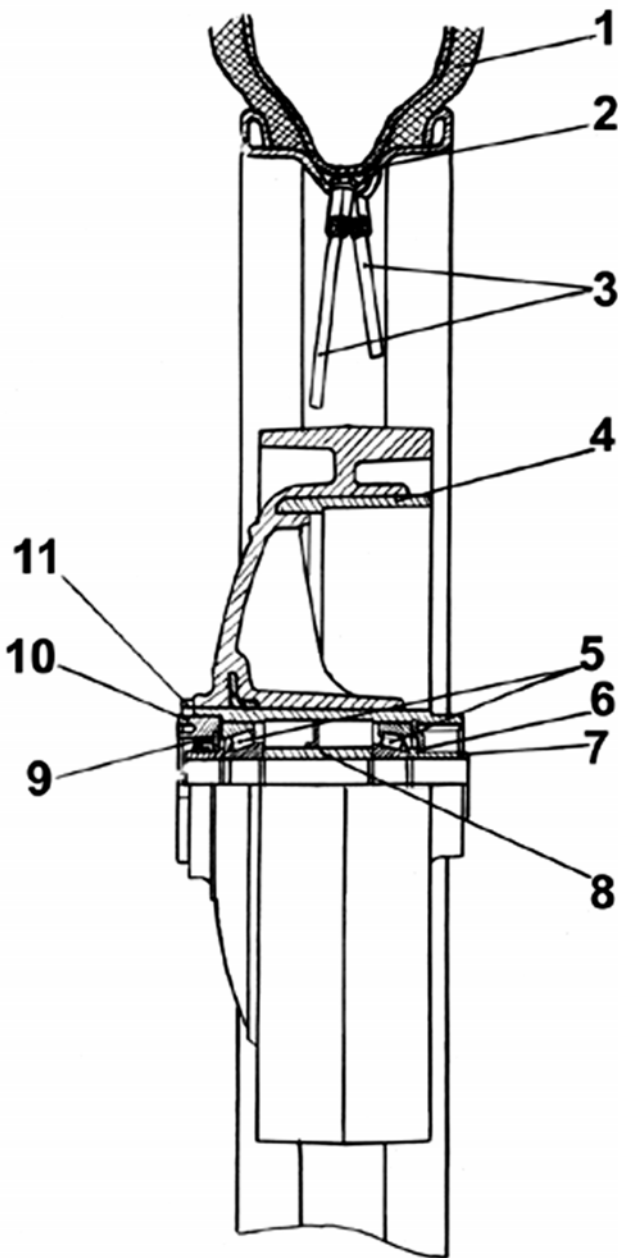

Chapter 9

BRAKES

BRAKES

The motorcycle is equipped with a hydraulic disc brake in front and manual shoe type brakes in the rear and sidecar. The hydraulic disc brake consists of a caliper, brake pads and a wheel disc. The manual shoe type brake consists of a drum, a drum cover, shoes and lever activated cams.

The **front wheel brake** is of the hydraulic disc type.

The **sidecar wheel brake** is connected to the rear brake pedal.

The sidecar brake drum cover is secured on the sidecar wheel axle and is held from rotation by a torque stop. Sidecar brake shoes are interchangeable with the motorcycle rear brake shoes.

The **rear wheel brake** is mounted in the final drive case, and is actuated via a mechanical linkage to the brake pedal.

The brake shoes are provided with adjusting bolts to compensate for the wear of the shoe linings. The adjusting bolts of the brake shoes may be used for adjusting the gap between the brake shoes and the brake drum.

For optimal performance of the brake, tighten the brake cable adjuster until there is just the slightest drag on the wheel. Then back off the adjustment 1 or 2 turns.

For checking the gap, the cover of the brake drum and final drive crankcase are provided with an inspection hole, closed with a rubber plug.

WARNING: *Never use the front brake to stop when the motorcycle is moving in reverse. Severe damage to the front brake caliper and mounting plate will occur.*

REAR BRAKE ADJUSTMENT

The foot brake is adjusted by an adjusting nut situated on the rear end of the brake tie rods. Proceed to adjustment of the foot brake starting from the rear wheel, having first slackened the nut on the tie rod of the sidecar wheel brake. Then adjust the sidecar wheel brake by tightening the nut on the brake tie rod. After the foot brake has been adjusted properly, back up the nut on the tie rod of the sidecar wheel brake by 2-3 turns to keep it from pulling to the right when applying the brake.



Rear brake adjustment nut

Brakes should be “burnished in” during the initial running in period. Follow burnishing procedures carefully. Make approximately 100 stops using 75% of full braking power. This can be done over several periods and need not be done in one session. Choose an area with clean, dry pavement and no obstructions. Travel in a straight line and apply both the hand (front) brake as well as the foot (rear and sidecar) brakes.

After burnishing the brake shoes, adjust your brakes on each wheel to reduce the gap between shoes and drums. This procedure will ensure maximum braking performance during the running-in period and is essential before raising your top speed, after your Ural has been carefully run in (after 1,500 km).

WARNING: *BECAUSE BRAKE PERFORMANCE IS A CRITICAL SAFETY ITEM, WE RECOMMEND THAT YOU SEE YOUR IMWA DEALER FOR THESE SERVICES.*

BRAKES MUST BE INSPECTED FOR WEAR AS PER THE SERVICE COUPONS *IF THE BRAKE SHOE FRICTION MATERIAL IS 1/16 IN. THICK OR LESS (THE THICKNESS OF A NICKEL) THE SHOES MUST BE REPLACED IMMEDIATELY. FAILURE TO REPLACE SHOES WHEN NECESSARY COULD RESULT IN BRAKE MALFUNCTION AND PERSONAL INJURY. IF YOU RIDE UNDER ADVERSE CONDITIONS, STEEP HILLS, HEAVY TRAFFIC, ETC., MORE FREQUENT INSPECTION, 1,000 KM OR LESS, WILL BE NECESSARY.*

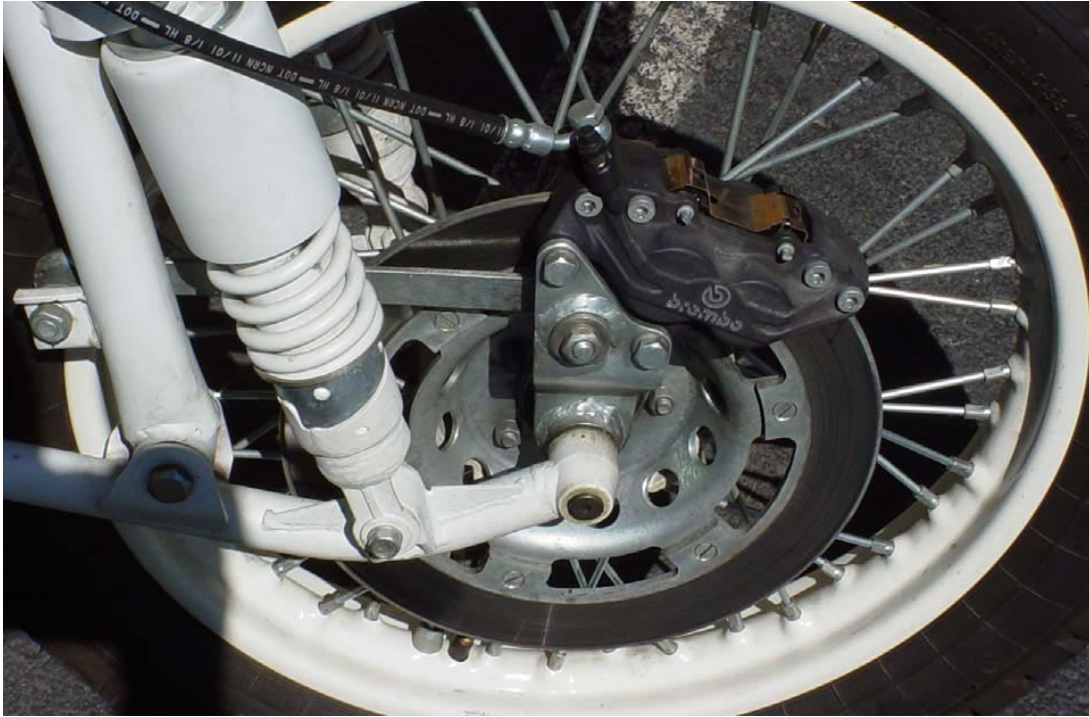

The front disc brakes require periodic inspection, but do not require adjustment. The brake pads can be inspected by removing the dust shield from the top of the caliper and checking the thickness of the pads. The pads should be replaced when less than 1/8 inch of pad is remaining on either pad. The brake hose should be inspected periodically for leaks and cracks along the length of the hose as well as the banjo fittings on either end.

WARNING: Never use any aftermarket brake hose for the front brake. Use only genuine Ural brake hoses, failure to do so could result in front brake failure and voiding the warranty.





Brake Reservoir

Check the front brake reservoir every service. Wipe off all dirt and avoid any contamination of the brake fluid in the reservoir. Refill the reservoir with only DOT approved 3 or 4 brake fluid. Be careful not to spill brake fluid on the paint, as damage to the paint may occur.

To check the brake fluid level in the reservoir, remove the two top screws on the reservoir. Remove the cover and the rubber gasket. Fill the reservoir to within 1/4 inch of the top. Squeeze the brake lever several times to ensure that any air that has been introduced is forced out of the system. Replace the rubber gasket, the cover and the two screws.

Chapter 11

ELECTRICAL EQUIPMENT

The electrical equipment of the motorcycle includes power supplies, auxiliary instruments and electric wiring.

Electric power supplies are a battery and an alternator with a built-in rectifier.

A single wire system is used for wiring the electric circuits, i.e. a single wire carries power to the electrical devices and the frame and engine serve as the second wire (called the "ground"). The negative pole of the battery is connected to the motorcycle frame through the battery master switch. The alternator makes electrical contact to the motorcycle engine and frame through its mounting bolts.

Battery supplies electric power to all the systems of the motorcycle when the engine (and alternator) have stopped.

An alternator with a built-in rectifier is driven by the engine camshaft driven gear. The alternator is secured with two studs on the engine crankcase. At the drive side, the alternator cover is so designed that by turning the alternator on the studs, the backlash adjustment of the gear mesh gap can be made.

Electric horn. The motorcycle is equipped with a horn which sounds when the ignition is on and the horn button is pressed. The horn can be tuned for loudest performance with an adjusting screw located at the rear portion of the horn body.

Headlight. A 7" diameter DOT approved sealed beam headlight is used on the Ural. Adjust it so that the high-beam is horizontal when the motorcycle is in its normal loaded condition.

The **stop light switch** is secured on the frame bracket by means of two nuts. If the stop light either stays on or doesn't come on, loosen the nuts and adjust the stop light switch position either up or down on the frame & retighten the two nuts.

Sidecar Spotlight
Switch



The sidecar spotlight, if equipped, is located on left side of the front of the sidecar. It is operated by activating the switch located just behind the spotlight. The spotlight can be aimed by moving the lever at the rear of the spotlight. Only use the spotlight when the motorcycle engine is running, otherwise the battery may become discharged.

WARNING: *Never tap into the spotlight circuit to add accessories. Damage to the motorcycle electrical system may result.*

Electrical Circuits

Lead acid batteries such as those found in motorcycles are designed for a charging voltage of 14.25 volts. Batteries which are subjected to greater than 14.25 volts for extended periods of time can suffer permanent damage due to the electrolyte boiling dry. Charging voltage of less than 14.25 volts will result in an inadequate charge delivered to the battery.

Automotive batteries operate at 12 volts. This is not enough voltage to harm people in any way. However, the battery stores a large amount of electricity in the form of electrons. If the electrons are allowed to flow from the battery without restriction, then the wires carrying the electricity will become hot enough to melt. The melting wires are extremely dangerous and can easily burn you.

Most problems in automotive electrical circuits are caused by poor connections. Make sure that all connection points are clean and tight.

If the flow of electricity through a wire is interrupted due to a break in the wire or a poor connection, then the circuit is said to be “an open circuit”

The flow of electricity through a circuit always takes the path of least resistance. If there is an accidental path of extremely low resistance created in a circuit, the circuit is said to have a “short circuit” A short circuit will usually result in the melting of the fuse protecting that circuit.

ELECTRICAL EQUIPMENT MAINTENANCE

During the daily preventive inspection, check the functioning and the condition of the electrical equipment. Inspect and or replace the spark plugs and ignition leads as required in the Service Coupons. The gap is readjusted by bending the end of the side electrode.

Care of alternator. In the course of daily inspection, check the fastening of wires to the alternator terminals, fastening of the alternator on the engine crankcase, backlash of the gears (by listening). In case of too little backlash of the drive gear, excessive wear and overheating of the alternator bearings take place.

Check for proper tightening of:

- nuts of the binding post bolts
- the alternator clamping screws
- the alternator fastening nuts

as often as outlined in the Service Coupons.

WARNING: Do not add any electrical accessories to your Ural motorcycle, as this will immediately void the warranty

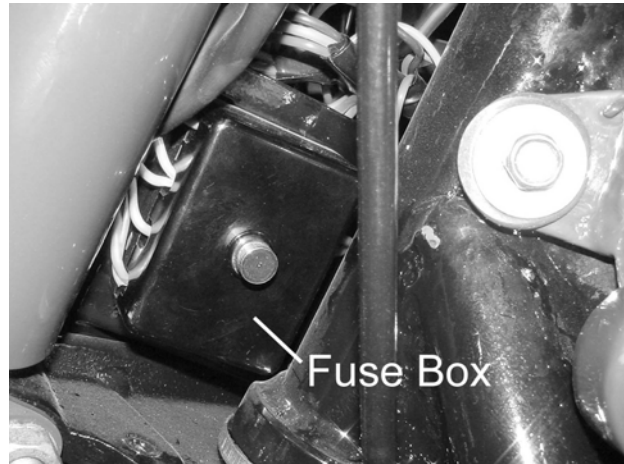

The fuse box is located beside the left front fork.

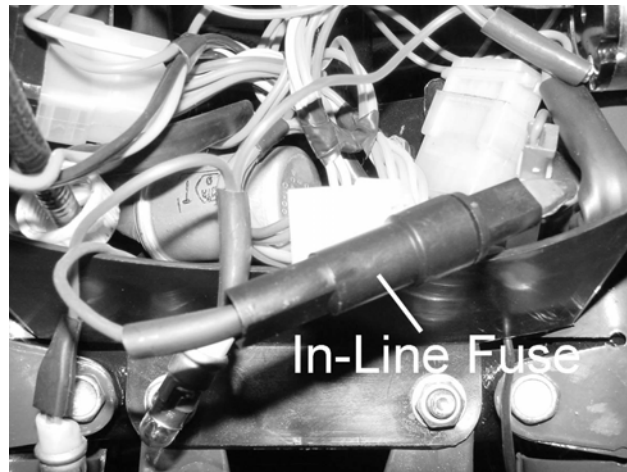

The #1 in-line fuse is located behind the headlight.

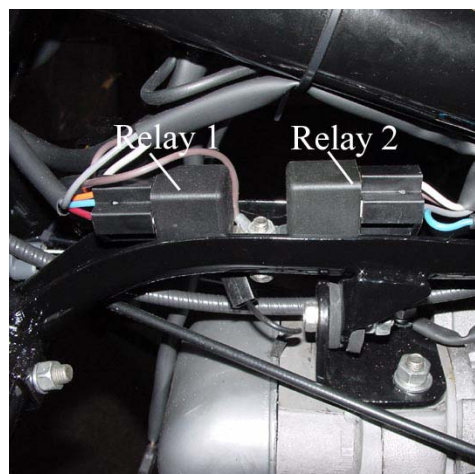

The headlight control relays # 1 & 2 are located underneath the fuel tank.

811001JSD1-8-ZW

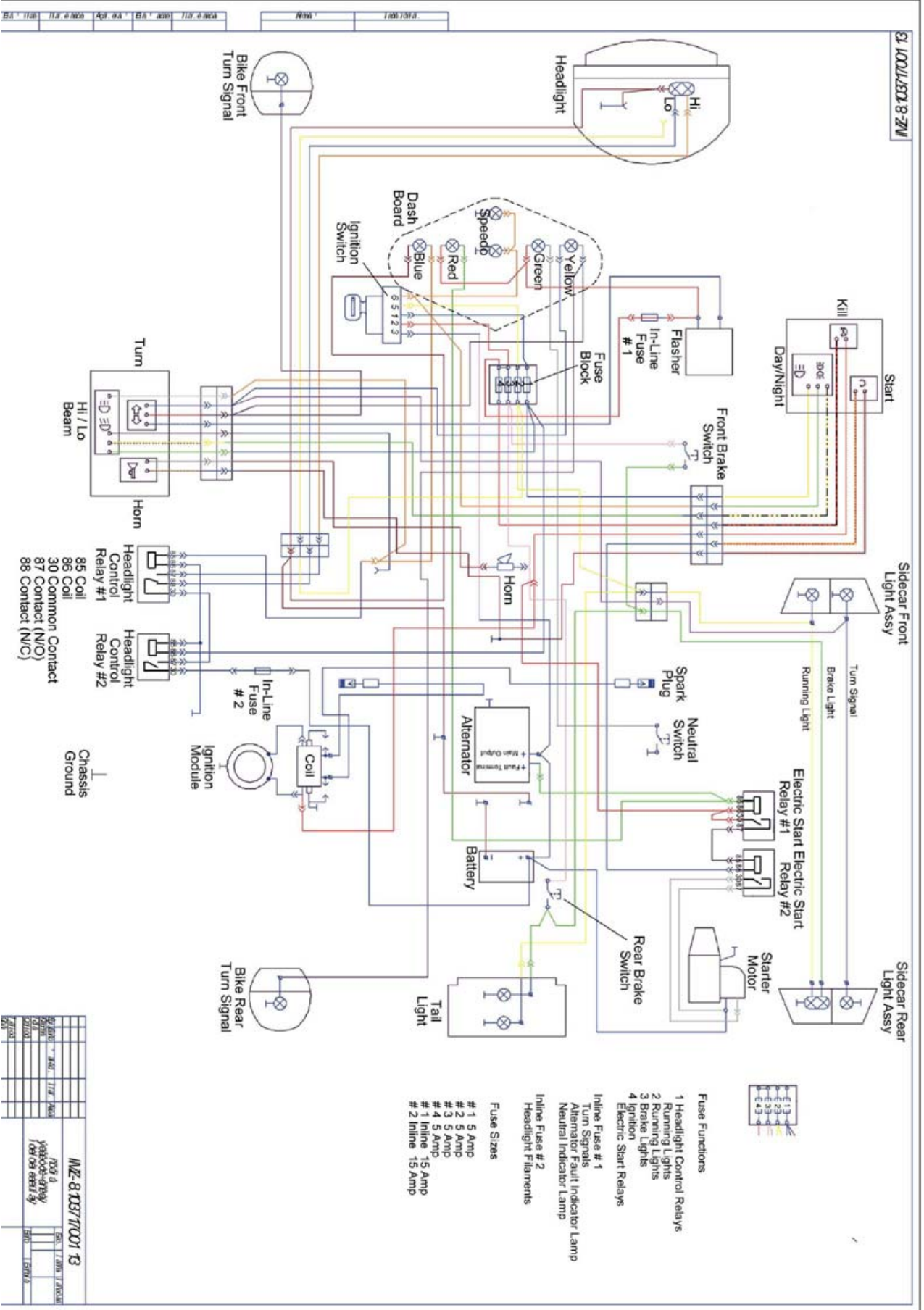

Fuse Functions

- 1 Headlight Control Relays
- 2 Running Lights
- 3 Brake Lights
- 4 Ignition
- Electric Start Relays

- In-Line Fuse # 1
- Turn Signals
- Alternator Fault Indicator Lamp
- Neutral Indicator Lamp
- Headlight Filaments

Fuse Sizes

- # 1 5 Amp
- # 2 5 Amp
- # 3 5 Amp
- # 4 5 Amp
- # 1 In-Line 15 Amp
- # 2 In-Line 15 Amp

M-Z-8-T037T001 13	
REV	DATE
1	11/18/11
2	01/19/12
3	03/20/12
4	04/19/12
5	05/15/12
6	06/15/12
7	07/15/12
8	08/15/12
9	09/15/12
10	10/15/12
11	11/15/12
12	12/15/12
13	01/15/13
14	02/15/13
15	03/15/13
16	04/15/13
17	05/15/13
18	06/15/13
19	07/15/13
20	08/15/13
21	09/15/13
22	10/15/13
23	11/15/13
24	12/15/13
25	01/15/14
26	02/15/14
27	03/15/14
28	04/15/14
29	05/15/14
30	06/15/14
31	07/15/14
32	08/15/14
33	09/15/14
34	10/15/14
35	11/15/14
36	12/15/14
37	01/15/15
38	02/15/15
39	03/15/15
40	04/15/15
41	05/15/15
42	06/15/15
43	07/15/15
44	08/15/15
45	09/15/15
46	10/15/15
47	11/15/15
48	12/15/15
49	01/15/16
50	02/15/16
51	03/15/16
52	04/15/16
53	05/15/16
54	06/15/16
55	07/15/16
56	08/15/16
57	09/15/16
58	10/15/16
59	11/15/16
60	12/15/16

Chapter 12

MAINTENANCE OF MOTORCYCLE

Maintenance should be performed after the specified total kilometers run irrespective of the mechanical condition of the motorcycle.

Different service duties and mechanical condition of the motorcycle may necessitate a change in the intervals.

The Lubrication Chart indicating lubrication points of the motorcycle is given in Fig. 35. A summary of lubrication maintenance is given in the lubrication chart.

Cosmetic Maintenance

The enjoyment and resale value of your vehicle is greatly enhanced by consideration to the “look” and cosmetic perfection of your vehicle. Due to the numerous metal surfaces on a sidecar rig, special care must be taken to prevent rust from occurring and/or to removed any rust or oxidation.

LIST OF RECOMMENDED LUBRICANTS

Lubrication Area	Detergent Oil Quantity
Engine	20w/50 Castrol 68 oz. (2.0 L) ¹
Transmission	20w/50 Castrol 34 oz. (1.0 L) ²
Single Wheel Final Drive	80/90 wt.Gearlube 3.5 oz. (105 ml)
Dual Wheel Final Drive	80/90 wt.Gearlube 4.5 oz. (135 ml)

1 68 ozs is an approximate measure. The exact oil quantity will be whatever is required to bring the oil level at the top mark of the dipstick.

2 34 ozs is an approximate measure. The exact oil quantity will be whatever is required to bring the oil level up to the bottom thread of the transmission oil filler hole.

Note: Since the Ural engine is of a traditional design, some leakage, seepage or dripping of oil and/or other lubricants is normal. It is not indicative of any malfunctioning and therefore is not covered as a warranty item unless motorcycle operation or safety are materially affected.

ENGINE
OIL FILL

GEARBOX
OIL FILL

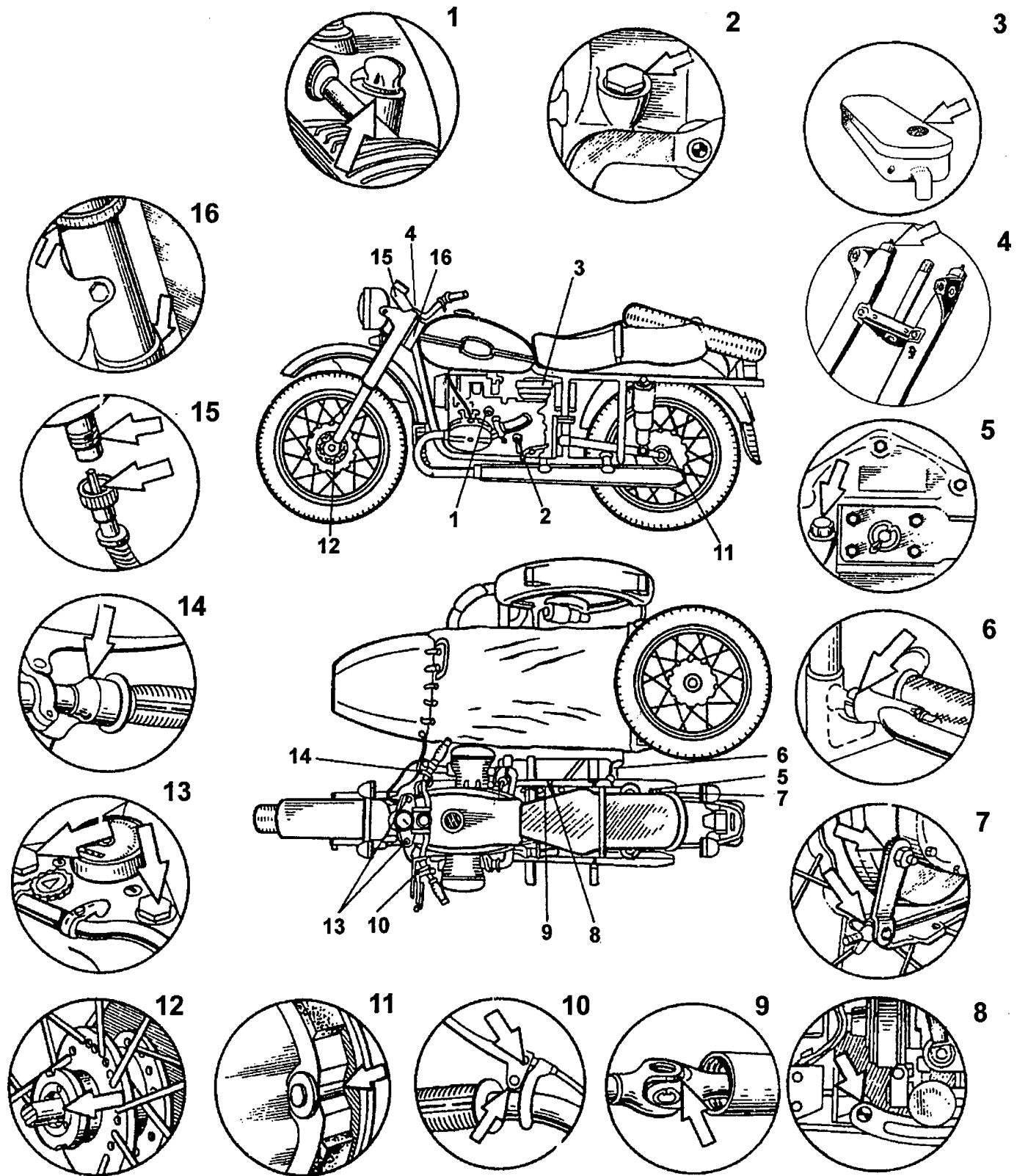

Fig. 35. Lubrication Chart

LUBRICATION CHART

ITEM	PART TO BE LUBRICATED	LUBRICANT
1	Engine crankcase	20W/50 Detergent Oil
2	Transmission	20W/50 Detergent Oil
3	Air cleaner	JR Filter Oil
4	Telescopic forks	5wt-10wt Fork Oil
5	Final Drive	80/90 Gear oil
6	Hinges of sidecar collet joint	Spindle oil & WD-40
7	Brake system hinge joints	Spindle oil & WD-40
8	Brake pedal shaft	Grease
9	Drive shaft universal joint	Grease
10	Lever pins & end pieces of clutch & hand brake cables	Grease
11	Pins & cams of brake shoes	Grease
12	Wheel bearing	Grease
13	Front forks	Spindle oil & WD-40
14	Carburetor throttle control twist grip	Grease
15	Speedometer flexible drive cable & speedometer axle	Spindle oil
16	Steering column bearings	Grease

REQUIRED LUBRICATION

The Ural has been certified for EPA with **SAE 20W/50 petroleum based detergent oil**. This oil is used in both the engine and transmission.

CARE OF MOTORCYCLE PAINT

When washing the motorcycle, use a weak stream of cold or slightly heated water. Never use a pressure washer! Do not remove dust and mud by rubbing the surface with a dry cloth as sand particles will degrade the surface and the paint will rapidly lose its brilliance. While washing, do not use soda solution, kerosene, citric acids or mineral oils. If the surface is stained with mineral oil, degrease by wiping with a rag. If after removal of mud and dust with a jet of water, some dirt is left on the surface, remove it with the help of a sponge, a soft hair brush or a flannel and water, but not allowing separate water drops to dry out on the surface. Finally, polish the painted surfaces with a dry soft flannel.

To repair painted areas, each motorcycle is furnished with a bottle of matching touch up paint.

For patching proceed as follows:

- clean the surface with turpentine
- rub the damaged spot with a waterproof abrasive cloth and water rub thoroughly
- paint using a soft brush or a spray gun.

After patching let the surface dry in air for 15 min, then proceed with drying at 212°F-248°F/ 100°C-120°C with the aid of heat reflector or an electric lamp until the coat is perfectly dry.

Bear in mind that enamels are flammable. Color match may not be perfect due to humidity, fading, temperature and other variables.

The painted surfaces of the motorcycle feature natural gloss. In case some dull spots appear, remedy them by polishing as follows. Take a solution of wax polishing compound and having washed the dull spots thoroughly, smear a thin film of the compound with a soft wad (cotton, cotton gauze or flannel) over the surface. Rub the polishing compound making circular motions with the wad. In 3 - 5 min. of drying, wipe the surface with a clean dry piece of cloth or flannel until luster appears.

PRESERVATION AND STORAGE

If the motorcycle is put in storage for the season, arrange it on supports and proceed with the preservation treatment. Check that the wheel tire pressure is within specifications. Store the motorcycle away from acids, alkalis, mineral fertilizers and other harmful substances.

Prior to placing it in storage, clean the bike thoroughly, drain the carburetors, or start the engine and let it run with the gasoline cock closed to remove gasoline in the float chambers of carburetors.

Then spray storage oil (WD-40) into each cylinder through the spark plug holes. Turn the crankshaft by depressing the kick lever pedal to distribute lubricant over the interior of the cylinders. Lubricate the surfaces of chrome and zinc plated parts with a rust inhibitor. Smear all the points provided with grease cups with commercial grease. Seal the outlet holes of the mufflers.

Before starting a trip on the motorcycle that was under preservation, proceed with the jobs listed in the section "Pre-Trip Preliminaries".

Winter Considerations

Motorists in many areas of the US experience the use of salt and other chemicals that are applied to road surfaces in the winter.

Salt or other caustic chemicals should always be removed from your bike's surfaces with fresh water as soon as possible.

Undercoating of fenders is recommended for those areas with salt and/or fine gravel or sand. See your dealer for details.

BATTERY

Storage batteries on the motorcycle should function at ambient air temperature from -40°C to plus 60°C/ 40°F to 140°F.

As the battery is in service:

- regularly check the voltage for 13.8 - 14.2 V
- do not allow the battery to discharge.
- use only distilled water to maintain the normal level of electrolyte.
- coat bolts, nuts, washers and tips with petroleum jelly or battery grease. Use two wrenches for clamping or undoing the nuts to avoid breaking battery parts.

Warning: Do not short the terminals together to check for sparking.

Before storage, fully charge the batteries, wash the battery surface with water and wipe dry, clean the bolts and nuts of dirt.

WARNING: BATTERIES CONTAIN SULFURIC ACID WHICH CAN CAUSE SEVERE BURNS. AVOID CONTACT WITH SKIN, EYES OR CLOTHING. **ANTIDOTE:** EXTERNAL — FLUSH WITH WATER. INTERNAL — DRINK LARGE QUANTITIES OF WATER FOLLOWED BY MILK OF MAGNESIA, VEGETABLE OIL, OR BEATEN EGGS. CALL DOCTOR IMMEDIATELY.

Caution: When charging the battery, disconnect the positive terminal (+) from the battery to prevent damage to the electrical components *Never jump-start the motorcycle!*

WARNING: BATTERIES PRODUCE EXPLOSIVE HYDROGEN GAS AT ALL TIMES — ESPECIALLY WHEN BEING CHARGED. KEEP CIGARETTES, OPEN FLAME, AND SPARKS AWAY FROM BATTERY AT ALL TIMES. VENTILATE AREA WHEN CHARGING BATTERY. ALWAYS PROTECT HANDS AND PROTECT EYES WITH SHIELD OR GOGGLES WHEN WORKING NEAR A BATTERY OR ACID. **KEEP BATTERIES AND ACID OUT OF THE REACH OF CHILDREN!**

CAUTION: If battery is filled to a higher level than specified, some of the solution will be forced out through the vent tube when battery is charging. This will not only weaken the solution, but also may damage parts near the battery. To prevent battery case damage caused by pressure buildup, be sure vent tube is properly routed and not kinked or obstructed.

LIST OF INDIVIDUAL TOOL SET, SPARE PARTS, ACCESSORIES & DOCUMENTS

DESCRIPTION	QTY	DESCRIPTION	QTY
Tools			
1. Wrench 7 x 8	1	1. Air Pump	1
2. Wrench 10 x 12	1	2. Air Pressure Gauge	1
3. Wrench 13 x 14	1	3. Ignition keys	2
4. Wrench 14 x 17	1		
5. Wrench 19 x 22	1		
6. Socket wrench 10 x 12	1		
7. Socket wrench 10 x 13	1	Set of Spares	
8. Socket wrench 19 x 21	1		
9. Wrench 27 mm	1	1. Oil filter element	1
10. Double head wrench	1	2. Fuses	2
11. Spanner wrench	1	3. Touch up paint	1
12. Spanner wrench assembly	1		
13. Screwdriver 150 mm	1	Documents	
14. Screwdriver 100 mm	1	1. Owner's Manual	1

- | | |
|--|---|
| 15. Punch | 1 |
| 16. Allen wrench | 1 |
| 17. 22mm Round wrench
(Patrol only) | 1 |

This page left intentionally blank

Chapter 13

GEAR UP AND PATROL MOTORCYCLE WITH ENGAGEABLE SIDECAR DRIVE

DESCRIPTION

When engaged by the operator for “off-road” use, the sidecar wheel is driven by a drive shaft connected with the motorcycle main drive with a universal joint.



Sidecar Drive Disengaged



Sidecar Drive Engaged

NOTE: *the sidecar drive should only be engaged when the motorcycle is stopped, and only when venturing “off-road”*

HANDLING DIFFERENCES FROM THE SINGLE WHEEL DRIVE

When the sidecar wheel is engaged, the motorcycle handles differently from the standard (single wheel drive) motorcycle. When the rear wheel and sidecar wheel are “locked” together on paved surfaces, maneuvering is very difficult. Forcing the rig to turn on paved surfaces with the sidecar drive engaged is extremely hazardous and can result in loss of control of the motorcycle. It also voids the warranty.

The dual wheel drive should be engaged whenever poor traction is encountered in any off-road condition such as mud, snow, streams, rocks, gravel, loose dirt, sand, etc. In these conditions the extra traction afforded by the sidecar wheel will be very helpful, especially if some weight is also added to the sidecar. Some difficulty in making sharp turns may still be noticed.

SIDECAR MAINTENANCE

Check before driving that the final drive swing arm, propeller shaft fork and sun gear flange are bolted tightly.

Grease the drive shaft splines sufficiently as outlined in the service coupons. Do not over grease the drive shaft splines as this may prevent the drive shaft from moving freely in the hub.

The sidecar wheel bearing requires periodic greasing.

WARNING: *The canister is not to be used for fuel or drinking water. The ammunition box is not to be used for the storage of live ammunition.*

NOTE: *Never leave the spotlight on when the motorcycle is not running. A dead battery may result.*

Chapter 14

LEARNING TO RIDE THE URAL MOTORCYCLE WITH SIDECAR ACCESSORY

The Ural sidecar motorcycle, since it has three wheels, behaves quite differently from either a solo motorcycle or a car. For these reasons the following label has been attached to your motorcycle tank:

WARNING: LEFT-HAND AND RIGHT-HAND TURNS MAY BE DANGEROUS. EXCESSIVE SPEED AND AN UNWEIGHTED SIDECAR MUST BE AVOIDED.

The bottom line is that, like any other motor vehicle, if the Ural is driven beyond its design limits, you can get hurt. Properly driven, since you have the added stability of the third wheel in case of sand, ice or slippery road conditions, the Ural will give you a much safer ride than a solo motorcycle.

Finally, you will enjoy the fact that the Ural will not expose you to tipping over at stop signs, which has happened all too frequently to beginners as well as experienced solo motorcycle drivers.

This manual is included with each new Ural sidecar motorcycle outfit. Before driving your new Ural, carefully study this manual from cover-to-cover, fill in the exam questions, review the manual to check your answers and practice all the maneuvers outlined in the manual before going out into traffic.

If possible, an experienced sidecar driver (preferably your Authorized IMWA dealer) should ride along during your first ride. If not, put about 100 LB of ballast in the sidecar during your initial training. Although an experienced driver can safely drive the Ural with an empty sidecar a beginner should always have ballast or a passenger in the chair.

Check with your local IMWA Dealer to find out your particular state's sidecar driver's license requirements.

When you accelerate, the Ural will pull slightly to the right due to the inertia and drag of the sidecar.

When you let off the gas it will pull slightly to the left due to the inertia of the sidecar.

Note: The Patrol with engageable sidecar wheel handles differently with the sidecar driveshaft engaged and cannot turn on paved roads. For this reason, the sidecar drive must only be engaged when operating the vehicle off-road or where snow, ice and mud conditions are encountered on road.

The best way to make friends with your Ural is to take it to a large, paved, non-congested parking lot. Practice starting and stopping from various speeds, shifting up and down, accelerating and decelerating in each gear, turning right and left at slow-to-medium speeds.

Finally, practice lifting the sidecar. To do this drive in a clockwise circle about 20 feet in diameter. Gradually increase your speed until the sidecar wheel lifts from the surface 6 - 12 inches. Then roll off the throttle and ease steering pressure on the grips so it gradually comes back down. Repeat doing this until you feel comfortable with the wheel in the air. Remember, the moment you roll off the throttle it will come down. When you have mastered "flying the chair" to the point where you can keep it in the air for a full circle you will have a good feel for the speed and turn radius that will lift the sidecar. Then carefully experiment with larger and smaller circles.

If, after gaining proficiency with the Ural, you plan to drive on the street with an empty sidecar, go back to the parking lot and practice the above maneuvers with an empty sidecar. You'll find that the sidecar will lift much more readily when it is empty, especially if you enter a decreasing radius turn (such as a freeway off ramp) at too high a speed. This is why we recommend generally carrying about 100 lbs. or more in the sidecar.

SAFE OPERATING RULES

Before operating your Ural it is your responsibility to read and follow operating and maintenance instructions in this manual and follow these basic rules for your personal safety.

- Know and respect the Rules of the Road in your state.
- Use only IMWA approved parts and accessories.
- Gasoline is extremely flammable and is explosive under certain conditions.
- Refuel in a well ventilated area with the engine stopped. Do not smoke or allow open flames or sparks when refueling or servicing the fuel system. Always close the fuel supply valve when the engine is not running to prevent flooding of the carburetors. Do not overfill fuel tank. Fill tank slowly to prevent fuel spillage. Leave air space to allow for fuel expansion. Do not fill more than about an inch below the lower edge of the tank filler.
- Motorcycle exhaust contains poisonous carbon monoxide gas. Do not inhale exhaust gases and never run the engine in a closed garage or confined area.
- Before starting engine, check for proper operation of brake, clutch, shifter, throttle controls, correct fuel and oil supply.
- A new motorcycle must be operated according to a special break-in procedure (see Running-In The New Motorcycle).
- Operate the motorcycle only at moderate speed and out of traffic until you have become thoroughly familiar with its operation and handling characteristics under all conditions. If you are an inexperienced rider we recommend that you obtain information and training in correct motorcycle riding technique.
- Do not exceed the legal speed limit or drive too fast for existing conditions. Always reduce speed when poor driving conditions exist. High speed increases the influence of any other condition affecting stability and the possibility of loss of control.
- Pay strict attention to road surfaces and wind conditions. Any two or three-wheeled vehicle may be subject to upsetting forces. Wind blasts from passing trucks, holes in the pavement, rough road surfaces, rider control error, etc., may influence the handling characteristics of your motorcycle. Should this happen, reduce speed and guide the motorcycle with a relaxed grip to a straightaway position. Do not brake abruptly or force the handlebars as this may aggravate an unstable condition. New riders should gain experience under various conditions while driving at moderate speeds.
- Operate your motorcycle defensively. Remember, a motorcycle does not afford the same protection as an automobile in an accident.
- Wear an approved helmet, clothing and footgear suited to motorcycle riding. Bright or light colors are best for greater visibility in traffic especially at night. Avoid loose flowing garments and scarves.
- The exhaust pipes and mufflers get very hot when the engine is running and remain too hot to touch for some time after the engine is shut off.
- Wear clothing that will completely cover the legs when riding and avoid contact with the exhaust system.
- Do not allow others, under any circumstances to operate your motorcycle

unless you are certain that they are experienced, licensed riders and are familiar with the operation of your particular motorcycle.

- When leaving the motorcycle unattended, remove ignition key from switch. Protect your motorcycle against theft.
- Safe motorcycle operation requires mental awareness and good judgment combined with a defensive driving attitude. Don't allow fatigue, alcohol or drugs to endanger your safety or the safety of others.
- Maintain your motorcycle in proper operating condition in accordance with the service coupons in this Owner's Manual. Particularly important to motorcycle stability is the tire inflation pressure, tread condition, and proper adjustment of wheel bearings and steering head bearings.
Do not operate motorcycle with loose, worn or damaged steering system or front or rear suspension system as handling will be adversely affected. Contact your dealer for repair of steering or suspension system wear or damage.
- Do not tow a trailer.
- At street intersections, give the right-of-way to the vehicle on your right. Do not presume too much when you have the right-of-way, the other driver may not know you have it.
- Always signal when preparing to stop or turn.
- All traffic signs, including those used for the control of traffic at intersections, should be obeyed promptly and to the letter. SLOW DOWN signs near schools and CAUTION signs at railroad crossings should always be observed and your actions governed accordingly.
- Never anticipate a traffic light. When a change is indicated from GO to STOP (or vice versa) in the traffic control systems at intersections, await the change.
- When intending to turn to the left, give signal at least 100 feet before reaching the turning point. Move over to the centerline of the street (unless local rules require otherwise), slow down passing the intersection of the street and then turn carefully to the left.
- In turning either right or left, watch for pedestrians as well as vehicles.
- Do not leave the curb or parking area without signaling and seeing that your way is clear to drive into moving traffic. A moving line of traffic has the right-of-way.
- See that your license tags are installed in the position specified by law and that they are clearly visible under all conditions. Keep them clean.
- Ride at a safe speed — a speed consistent with the type of highway you are on, and always note whether the road is dry, oily, icy or wet. Each varying condition on the highway means adjusting your speed accordingly.

Chapter 15

Ural Motorcycles Warranty Agreement

Irbit MotorWorks of America, Inc., (IMWA, Inc.) warrants to the first retail purchaser of the URAL® motorcycle from an Authorized IMWA Dealer and each subsequent owner that the motorcycle is free from defects in materials and workmanship for the period stated below.

To Qualify For This Warranty

- The URAL® motorcycle must be purchased from a Dealer within the United States who is authorized by IMWA, Inc. to sell motorcycles. (See www.imz-ural.com for the authorized IMWA Dealer list)
- Prior to delivery to the purchaser, the Dealer who is authorized by IMWA, Inc. to sell motorcycles must perform set-up and pre-delivery service.

Warranty Time Period

- Duration: two (2) years parts and labor.
- There is no mileage limitation.
- Coverage begins the date the motorcycle is sold to the first retail purchaser and the warranty registration card is received by IMWA, Inc.

Warranty Coverage

- IMWA, Inc. will repair or replace, at its options, any part (including parts of the emission control systems) that is found to be defective in material or workmanship under normal use for the applicable time period.
- In cases when warranty repair takes longer than 14 days, the warranty time period (see **Warranty Time Period**) is extended for the time period of repair, during which the motorcycle could not be ridden due to failures.
- IMWA, Inc. provides warranty for spare parts for the following period of time starting from the time of purchase of the parts by a Dealer or retail customer.
 1. Engine – 12 months
 2. Gearbox – 12 months
 3. Final drive – 12 months
 1. Alternator – 6 months
 2. Electric starter – 6 months
 3. Ignition – 6 months
 4. The rest of the motorcycle parts and parts assemblies - 30 days

The above applies ONLY in cases when Dealer or retail customer identifies defects before using parts and/or assemblies or these defects are identified during performance AND provided these parts have been properly installed by IMWA, Inc. or authorized IMWA Dealer.

- IMWA, Inc. will reimburse non-IMWA repair shops performing warranty repair for labor only if all the warranty processing and approval procedures are completely fulfilled and/or carried out according to IMWA, Inc. guidelines stated in the Warranty Claim Filing Procedures.

**Warranty Disclaimers
Limitations & Exclusions
Disclaimer of Consequential Damage & Limitation of Implied Warranties**

Irbit MotorWorks of America, Inc. disclaims any responsibility for:

- Loss of time due to warrantable issue
- Loss of use of motorcycle
- Transportation expenses
- Any other incidental or consequential damage (i.e. storage)

Duration of Implied Warranties

Any implied warranties, including the implied warranty of merchantability and fitness for a particular purpose are limited to the duration of this written warranty.

State Laws May Vary

The previous listed limitations or exclusions may not apply to a motorcycle because of state laws. Some states may not allow limitations on how long an implied warranty lasts. Some states may not allow exclusion or limitation of incidental or consequential damages.

These Warranties Do Not Cover:

3. Failures or required services that are not due to a defect in material or factory workmanship
4. Parts or accessories affected or damaged by:
 - Lack of required maintenance
 - Owner abuse
 - Accident and/or collision
 - Misuse
 - Normal wear
 - Neglect
 - Improper installation
 - Unsuitable use in an application for which the part was not designed
 - The incorporation or use of unsuitable attachments or parts
 - The unauthorized alteration of any part or system
 - Deterioration from the elements
 - Failure to follow running-in (break-in) procedure
5. Replacement of expendable maintenance items beyond the first scheduled maintenance, including, but not limited to:
 - spark plugs
 - filters
 - lubricants
 - compliance fittings
 - tires (see Owners Manual)
 - gaskets
 - fuel line
 - fuses
 - bulbs

These Warranties Do Not Cover: (continued)

6. Paint and/or decal fading, peeling, blistering, chipping or rusting.
7. Use for the following activities; such use will VOID coverage:
 - Racing
 - Competition
 - Rental or other commercial use
 - Alteration of engine or drive train
 - Any operation or use outside of that described in Owner's Manual
8. Alteration of the odometer so that the actual mileage cannot be determined; alteration will VOID coverage.
9. Use of bike for towing purpose will VOID warranty

Please refer to the Owner's Manual section for a listing of warranty exclusions for other items and circumstances that are not covered.

Dealer's and Owner's Responsibilities

Dealer Is Responsible to:

- Thoroughly check and road test new units before delivery.
- Fill out , sign and send Warranty Registration and Card of Delivery to IMWA, Inc. within 3 business days of the sale of Motorcycle.
- Accept all eligible motorcycles for warranty service regardless of selling Dealer.
- Keep records of all warranty work.
- Attend service schools as provided by IMWA, Inc.
- Submit warranty claims to IMWA, Inc. IN WRITING within 10 business days of the repair date.
- Obtain authorizations for warranty repairs from IMWA, Inc. when estimated cost will exceed \$100.00 (see Advance Warranty Authorization).
- Send failed parts and/or parts assemblies for an inspection to IMWA, Inc. within 3 (three) business days upon IMWA's request at IMWA, Inc. shipping expense.
- Provide digital pictures of failed parts and/or parts assemblies immediately upon IMWA's request.

Customer Is Responsible to:

- Operate and maintain the motorcycle according to the IMWA, Inc. Owner's Manual and service schedule.
- Retain all service records for future reference.

CALIFORNIA EMISSION CONTROL SYSTEM WARRANTY STATEMENT YOUR WARRANTY RIGHTS AND OBLIGATIONS

The California Air Resources Board and Irbit MotorWorks of America, Inc. (hereinafter IMWA) is pleased to explain the Emission Control System Warranty on your 2005 and later motorcycle. In California, new motor vehicles must be designed, built and equipped to meet the State's stringent anti-smog standards. IMWA must warrant the emission control system on your motorcycle for the periods of time listed below provided there has been no abuse, neglect or improper maintenance of your motorcycle.

Your emission control system may include parts such as the carburetor, the ignition system, catalytic converter, and engine computer. Also included may be hoses, belts, connectors and other emission-related assemblies. Where a warrantable condition exists, IMWA will repair your motorcycle at no cost to you including diagnosis, parts and labor.

MANUFACTURER'S WARRANTY COVERAGE

Class III motorcycles (280cc and larger): for a period of use of five (5) years or 30,000 kilometers (18,641 miles), whichever first occurs. If an emission-related part on your motorcycle is defective, the part will be repaired or replaced by IMWA. This is your emission control system DEFECTS WARRANTY.

OWNER'S WARRANTY RESPONSIBILITIES

- As the owner of Ural motorcycle, you are responsible for the performance of the required maintenance listed in your owner's manual. IMWA recommends that you retain all receipts covering maintenance on your motorcycle, but IMWA cannot deny warranty solely for the lack of receipts or for your failure to ensure the performance of all scheduled maintenance.
- You are responsible for presenting your motorcycle to an IMWA dealer as soon as a problem exists. The warranty repairs should be completed in a reasonable amount of time not to exceed 30 (thirty) days.
- As the motorcycle owner, you should also be aware that IMWA may deny you warranty coverage if your motorcycle or a part has failed due to abuse, neglect, improper maintenance or unapproved modifications.

If you have any questions regarding your warranty rights and responsibilities, you should contact Irbit MotorWorks of America at 1-888-990-8484 or the California Air Resource Board at 9528 Telstar Avenue, El Monte, CA 91731.

LIMITED WARRANTY ON EMISSION CONTROL SYSTEM

Irbis MotorWorks of America, Inc., 15411 NE 95th St, Redmond, WA 98052, USA (hereinafter IMWA) warrants that each new 2004 and later Ural motorcycle, that includes as standard equipment a headlight, taillight and stoplight, and is street legal:

- A. is designed, built and equipped so as to conform at the time of initial retail purchase with all applicable regulations of the United States Environmental Protection Agency, and the California Air Resources Board; and
- B. is free from defects in material and workmanship which cause such motorcycle to fail to conform with applicable regulations of the United States Environmental Protection Agency or the California Air Resources Board for a period of use, depending on the engine displacement: of 30,000 kilometers (18,641 miles), if the motorcycle's engine displacement is 280 cubic centimeters or greater or 5 (five) years from the date of initial retail delivery, whichever first occurs.
- I. **COVERAGE.** Warranty defects shall be remedied during customary business hours at any authorized IMWA motorcycle dealer located within the United States of America in compliance with the Clean Air Act and applicable regulations of the United States Environmental Protection Agency and the California Air Resources Board. Any part or parts replaced under this warranty shall become the property of IMWA.

In the State of California only, emission related warranted parts are specifically defined by the state's Emission Warranty Parts List. These warranted parts are: carburetors, electronic valves, air box, air cleaner element, spark plug, ignition coil, ignition control valve module, catalyist, carbon absorber, operating valve for vacuum control.

In the State of California only, Emission Control System emergency repairs, as provided for in the California Administrative Code, may be performed by other than an authorized IMWA dealer. An emergency situation occurs when an authorized IMWA dealer is not reasonably available, a part is not available within 30 (thirty) days, or a repair is not complete within 30 days. Any replacement part can be used in an emergency repair. IMWA will reimburse the owner for the expenses, including diagnosis, not to exceed IMWA's suggested retail price for all warranted parts replaced and labor charges based on IMWA's recommended time allowance for the warranty repair and the geographically appropriate hourly labor rate. The owner may be required to keep receipts and failed parts in order to receive compensation.

- II. **LIMITATIONS.** This Emission Control System warranty shall not cover any of the following:
 - . Repair or replacement required as a result of
 - (1) Accident
 - (2) Misuse

- (1) Repairs improperly performed or replacements improperly installed
- (4) Use of replacement parts or accessories not conforming to IMWA specifications which adversely affect performance and/or
- (1) Use in competitive racing or related events.
 - . Inspections, replacement of parts and other services and adjustments required for required maintenance
 - . Any motorcycle on which the odometer mileage has been changed so that actual mileage cannot be readily determined.

III. LIMITED LIABILITY

- . The liability of IMWA under this Emission Control System Warranty is limited solely to the remedying of defects in material or workmanship by an authorized IMWA motorcycle dealers at its place of business during customary business hours. This warranty does not cover inconvenience or loss of use of the motorcycle or transportation of the motorcycle to or from the IMWA dealer. IMWA SHALL NOT BE LIABLE FOR ANY OTHER EXPENSES, LOSS OR DAMAGE, WHETHER DIRECT, INCIDENTAL, CONSEQUENTIAL OR EXEMPLARY ARISING IN CONNECTION WITH THE SALE OR USE OF OR INABILITY TO USE THE IMWA MOTORCYCLE FOR ANY PURPOSE. SOME STATES DO NOT ALLOW THE EXCLUSION OR LIMITATION OF ANY INCIDENTAL OR CONSEQUENTIAL DAMAGES, SO THE ABOVE LIMITATIONS MAY NOT APPLY TO YOU.
- . NO EXPRESS EMISSION CONTROL SYSTEM WARRANTY IS GIVEN BY IMWA EXCEPT AS SPECIFICALLY SET FORTH HEREIN. ANY EMISSION CONTROL SYSTEM WARRANTY IMPLIED BY LAW, INCLUDING ANY WARRANTY OF MERCHANTABILITY OR FITNESS FOR A PARTICULAR PURPOSE, IS LIMITED TO THE EXPRESS EMISSION CONTROL SYSTEM WARRANTY TERMS STATED IN THIS WARRANTY. THE FOREGOING STATEMENT OF WARRANTY ARE EXCLUSIVE AND IN LIEU OF ALL OTHER REMEDIES. SOME STATES DO NOT ALLOW LIMITATIONS ON HOW LONG AN IMPLIED WARRANTY LASTS SO THE ABOVE LIMITATIONS MAY NOT APPLY TO YOU.
- . No dealer is authorized to modify this IMWA Limited Emission Control System Warranty.

IV. LEGAL RIGHTS. THIS WARRANTY GIVES YOU SPECIFIC LEGAL RIGHTS, AND YOU MAY ALSO HAVE OTHER RIGHTS, WHICH VARY FROM STATE TO STATE.

V. THIS WARRANTY IS IN ADDITION TO THE IMWA LIMITED MOTORCYCLE WARRANTY.

VI. ADDITIONAL INFORMATION. Any replacement part that is equivalent in performance and durability may be used in the performance of any maintenance or repairs. However, IMWA is not liable for these parts. The owner is responsible for the performance of all required maintenance. Such maintenance may be performed at a service establishment or by any individual. The warranty period begins on the date the motorcycle is delivered to an ultimate purchaser.

Warranty Processing

Warranty Shipping

All warranty parts are shipped by UPS Ground or Priority Mail (USPS) paid by IMWA, Inc. If Dealer elects to upgrade to faster shipping service, Dealer agrees to pay full cost of shipping, which will be billed to Dealer's account.

Warranty Disputes

A Dealer may contest a decision by the warranty department regarding a claim rejection or approved amount within 30 days of notification/receipt of credit memo. This must be done in writing along with a copy of the claim in question. After review, the Dealer will be notified of IMWA's findings. This decision will be final.

Factory Technical and Service Bulletins and Directives

When the Dealer receives a service bulletin or directive, the Dealer is responsible for notifying affected customers. These bulletins or directives should be given the highest possible priority. Please make sure your staff is aware and insure they all understand the topics covered. A copy of the bulletin or directive should be posted in a highly visible place in the Dealership's service department. Dealer will maintain a separate binder for the Tech and Service Bulletins to be available to the technicians for review.

Contacting IMWA, Inc. Warranty Department

IMWA, Inc. Warranty Department may be contacted by calling (425) 702-8484, faxing (425) 696-0834 or e-mailing (warranty@imz-ural.com) IMWA, Inc. When calling, please have all necessary information readily available. When faxing/e-mailing, please supply copies of all warranty information.

Agreed:

(Dealer's Trade Name)

By: _____
(Signature) Date

(Title) _____

Chapter 16

SERVICE COUPONS

IMPORTANT

Long and trouble-free enjoyment of your URAL motorcycle depends on following the recommendations outlined throughout the manual and summarized in Chapter 3, together with regular and proper servicing according to the service coupons provided on the following pages.

Dependable performance may be anticipated if your motorcycle is entrusted for maintenance to an Authorized IMWA URAL Dealer. A current list of Authorized IMWA URAL dealers may be obtained from our web site www.imz-ural.com or by sending a self-addressed stamped envelope to:

Irbit Motorworks of America
15411 NE 95th ST.
Redmond, WA 98052

Authorized IMWA URAL Dealers carry spare parts, have special tools for disassembling the motorcycle and employ experienced specialists to service and repair this motorcycle. Make it a practice to have your motorcycle serviced regularly at the mileage indicated on the Service Coupons.

An owner who is qualified and capable of doing his or her own service work is allowed to do so, without voiding the manufacturer's warranty, PROVIDED that you sign the Service Coupon and date it after the work has been performed.

WARNING: *FOR YOUR PERSONAL WELFARE, ALL THE LISTED SERVICE AND MAINTENANCE RECOMMENDATIONS IN THIS MANUAL SHOULD BE FOLLOWED BECAUSE THEY MAY AFFECT THE SAFE OPERATION OF YOUR MOTORCYCLE.*

Note: The performance of new motorcycle initial service is required to keep your new motorcycle warranty in force and to ensure proper emissions system operation.

WARNING: *STOP THE ENGINE AND SUPPORT THE MOTORCYCLE SECURELY BEFORE PERFORMING ALL SERVICE PROCEDURES. SERVICE SHOULD BE PERFORMED IN AN ADEQUATELY LIGHTED AND VENTILATED WORK AREA USING THE PROPER TOOLS. WHEN WORKING ON THE MOTORCYCLE, DO NOT SUPPORT MOTORCYCLE BY PLACING SUPPORTS UNDER BRAKE PEDAL. DAMAGE TO THE BRAKE SYSTEM COULD OCCUR CAUSING POSSIBLE MALFUNCTION AND PERSONAL INJURY.*

SERVICE COUPON NO 1. 500 KM
(To be performed between 400 to 600 km)

Date _____

Odometer reading _____ km

1. Change engine oil and filter.
2. Change transmission oil.
3. Change final drive oil.
4. Check condition of the gasoline petcock, remove any contaminants, replace in-line fuel filters.
5. Check carburetors while idling for synchronous operation.
6. Check tension of wheel spokes.
7. Check fasteners for proper tightening.
8. Check steering column bearings.
9. Check alternator bolts
10. Check brake fluid reservoir

The maintenance above has been performed as described.

Owner's Signature

Service Technician's Signature

SERVICE COUPON NO 2. 2,500 KM
(To be performed between 2,400 to 2,600 km)

Odometer reading _____ km

1. Change engine oil and filter. (*See Lubrication List, chapter 11*)
2. Check final drive oil level.
3. Inspect air filter element.
4. Check fasteners for proper tightening.
5. Check steering column bearings.
6. Check all wheels for correct bearing adjustment.
7. Check brake fluid reservoir.

The maintenance above has been performed as described.

Owner's Signature _____

Service Technician's Signature _____

SERVICE COUPON NO. 3. 5,000 KM
(To be performed between 4,900 to 5,100 km)

Date _____

Odometer reading _____ km.

1. Change engine oil and filter. *(See Lubrication List, chapter 11)*
2. Check transmission oil level.
3. Check final drive oil level.
4. Inspect air filter element.
5. Check condition of the gasoline petcock, remove any contaminants, replace in-line fuel filters
6. Check carburetors while idling for synchronous operation.
7. Check :
 - A Adjustment of steering column bearings.
 - B Tension of wheel spokes
8. Lubricate:
 - A Lever pins, thimbles of clutch and brake control cables
 - B Hinges of the foot brake pedal shaft and linkage.
9. Check condition and action of brakes.
10. Check tires for tread depth greater than 3/32"
11. Check fasteners for proper tightening.
12. Check brake fluid reservoir.

The maintenance above has been performed as described.

Owner's Signature _____

Service Technician's Signature _____

SERVICE COUPON NO. 4. 7,500 KM
(To be performed between 7,400 to 7,600 km)

Date _____

Odometer reading _____ km.

1. Change engine oil. *(See Lubrication List, chapter 11)*
2. Check final drive oil level.
3. Inspect air filter element.
4. Check fasteners for proper tightening.
5. Check steering column bearings.
6. Check adjustment of wheel bearings.

The maintenance above has been performed as described.

Owner's Signature _____

Service Technician's Signature _____

SERVICE COUPON NO. 5. 10,000 KM
(To be performed between 9,900 to 10,100 km)

Date _____

Odometer reading _____ km.

1. Change engine oil and filter. *(See Lubrication List, chapter 11)*
2. Change transmission oil. *(See Lubrication List, chapter 11)*
3. Change final drive oil. *(See Lubrication List, chapter 11)*
4. Inspect air filter element.
5. Torque cylinder head stud nuts.
6. Adjust valve tappet clearance.
7. Change oil in front fork shock absorbers (on telescopic fork models)
8. Replace the spark plugs and inspect ignition leads.
9. Replace in-line fuel filters.
10. Check:
 - A Carburetors while idling for synchronous operation
 - B Check steering column bearings & adjust if required.
 - C The condition and action of the brakes, lubricate the brake shoe fulcrum pins and cams.
 - D The tension of wheel spokes. Adjust if necessary.
 - E The toe-in and camber angle of the motorcycle and sidecar.
 - F Electric wiring. Tighten connections if required.
 - G Fasteners for proper tightening.
11. Repack the grease in wheel bearings, adjust the bearings.
12. Lubricate:
 - A Foot brake pedal shaft
 - B Hinges of foot brake pedal shaft and linkage.
 - C Lever pins and thimbles of clutch and front wheel brake control cables.
 - D Drive shaft splines
13. Check battery electrolyte level.
14. Check tires, tread depth greater than 3/32"
14. Check the timing.
15. Check brake fluid reservoir.

The maintenance above has been performed as described.

Owner's Signature

Service Technician's Signature

SERVICE COUPON NO. 6. 12,500 KM
(To be performed between 12,400 to 12,600 km)

Date _____

Odometer reading _____ km

1. Change engine oil. *(See Lubrication List, chapter 11)*
2. Check final drive oil level.
3. Inspect air filter element.
4. Check fasteners for proper tightening.
5. Check adjustment of wheel bearings.

The maintenance above has been performed as described.

Owner's Signature

Service Technician's Signature

SERVICE COUPON NO. 7 15,000 KM
(To be performed between 14,900 to 15,100 km)

Date _____

Odometer reading _____ km

1. Change engine oil and filter. *(See lubrication, chapter 11)*
2. Change transmission oil. *(See lubrication, chapter 11)*
3. Inspect air filter element
4. Check carburetors while idling for synchronous operation.
5. Check adjustment of steering column bearings.
6. Lubricate:
 - A Lever pins
 - B Hinges of the foot brake pedal shaft and linkage
7. Check condition and action of brakes
8. Check adjustment of wheel bearings.
9. Check tires for tread depth greater than 3/32".
10. Check fasteners for proper tightening.

The maintenance above has been performed as described.

Owner's Signature

Service Technician's Signature

SERVICE COUPON NO. 8. 17,500 KM
(To be carried out within 17,400 to 17,600 km)

Date _____

Odometer reading _____ km

1. Clean the air filter, .
2. Change oil in the engine and transmission. (*See Lubrication List, chapter 11*)
3. Check condition of the gasoline petcock, remove any contaminants, clean and blow out.

4. Check carburetors while idling for synchronous operation.
5. Check final drive gear oil level. (*See Lubrication List, chapter 11*)
6. Lubricate foot brake pedal shaft.
7. Check fasteners for proper tightening.
8. Adjust steering column bearings.
9. Check battery electrolyte level and fluid level.
10. Check air gap in electronic ignition between pickup and rotor (0.010 in).

The maintenance above has been performed as described.

Owner's Signature

Service Technician's Signature

SERVICE COUPON NO. 9. 20,000 KM
(To be performed between 19,900 to 20,100 km)

Date _____

Odometer reading _____ km.

1. Change engine oil and filter. *(See Lubrication List, chapter 11)*
2. Change transmission oil. *(See Lubrication List, chapter 11)*
3. Change final drive oil. *(See Lubrication List, chapter 11)*
4. Inspect air filter element.
5. Torque cylinder head stud nuts.
6. Adjust valve tappet clearance.
7. Change oil in front fork shock absorbers (on telescopic fork models)
8. Replace the spark plugs and inspect ignition leads.
9. Replace in-line fuel filters.
10. Check:
 - A Carburetors while idling for synchronous operation
 - B Check steering column bearings & adjust if required.
 - C The condition and action of the brakes, lubricate the brake shoe fulcrum pins and cams.
 - D The tension of wheel spokes. Adjust if necessary.
 - E The toe-in and camber angle of the motorcycle and sidecar.
 - F Electric wiring. Tighten connections if required.
 - G Fasteners for proper tightening.
11. Repack the grease in wheel bearings, adjust the bearings.
12. Lubricate:
 - A Foot brake pedal shaft
 - B Hinges of foot brake pedal shaft and linkage.
 - C Lever pins and thimbles of clutch and front wheel brake control cables.
 - D Drive shaft splines
13. Check battery electrolyte level.
14. Check tires, tread depth greater than 3/32"
14. Check the timing.

The maintenance above has been performed as described.

Owner's Signature

Service Technician's Signature

The maintenance above has been performed as described.

SERVICE COUPON NO. 10. 22,500 KM
(To be performed between 22,400 to 22,600 km)

Date _____

Odometer reading _____ km

1. Change engine oil. (*See Lubrication List, chapter 11*)
2. Check final drive oil level.
3. Inspect air filter element.
4. Check fasteners for proper tightening.
5. Check steering column bearings.
6. Check adjustment of wheel bearings.

The maintenance above has been performed as described.

Owner's Signature

Service Technician's Signature

SERVICE COUPON NO. 11. 25,000 KM
(To be performed between 24,900 to 25,100 km)

Date _____

Odometer reading _____ km.

1. Change engine oil and filter. (*See Lubrication List, chapter 11*)
2. Change transmission oil. (*See Lubrication List, chapter 11*)
3. Inspect air filter element.
4. Check carburetors while idling for synchronous operation.
5. Check:
 - A Adjustment of steering column bearings.
 - B Tension of wheel spokes
 - C Toe-in and camber of the motorcycle and sidecar
6. Lubricate:
 - A Lever pins
 - B Foot brake pedal shaft
 - C Hinges of the foot brake pedal shaft and linkage.
7. Check condition and action of brakes
8. Check tires for tread depth greater than 3/32"
9. Check fasteners for proper tightening.

The maintenance above has been performed as described.

Owner's Signature

Service Technician's Signature

SERVICE COUPON NO 12. 27,500 KM
(To be performed between 27,400 to 27,600 km)

Date _____

Odometer reading _____ km

1. Change engine oil. (*See Lubrication List, chapter 11*)
2. Check final drive oil *level*.
3. Inspect air filter element.
4. Check fasteners for proper tightening.
5. Check steering column bearings.
6. Check adjustment of wheel bearings.

The maintenance above has been performed as described.

Owner's Signature

Service Technician's Signature

SERVICE COUPON NO. 13. 30,000 KM
(To be performed between 29,900 to 30,100 km)

Date _____

Odometer reading _____ km.

1. Change engine oil and filter. *(See Lubrication List, chapter 11)*
2. Change transmission oil. *(See Lubrication List, chapter 11)*
3. Change final drive oil. *(See Lubrication List, chapter 11)*
4. Inspect air filter element.
5. Torque cylinder head stud nuts.
6. Adjust valve tappet clearance.
7. Change oil in front fork shock absorbers (on telescopic fork models)
8. Replace the spark plugs and inspect ignition leads.
9. Replace in-line fuel filters.
10. Check:
 - A Carburetors while idling for synchronous operation
 - B Check steering column bearings & adjust if required.
 - C The condition and action of the brakes, lubricate the brake shoe fulcrum pins and cams.
 - D The tension of wheel spokes. Adjust if necessary.
 - E The toe-in and camber angle of the motorcycle and sidecar.
 - F Electric wiring. Tighten connections if required.
 - G Fasteners for proper tightening.
11. Repack the grease in wheel bearings, adjust the bearings.
12. Lubricate:
 - A Foot brake pedal shaft
 - B Hinges of foot brake pedal shaft and linkage.
 - C Lever pins and thimbles of clutch and front wheel brake control cables.
 - D Drive shaft splines
13. Check battery electrolyte level.
14. Check tires, tread depth greater than 3/32"
15. Check the timing.

The maintenance above has been performed as described.

Owner's Signature

Service Technician's Signature

NEW ADDRESS FORM

If you move, please fill out this form and mail to the address below. This will insure that you continue to receive all correspondence from Irbid Motorworks of America.

VEHICLE IDENTIFICATION NUMBER

--	--	--	--	--	--	--	--	--	--	--	--	--	--	--	--	--	--	--	--

OWNER'S NAME _____

OLD ADDRESS _____ APT. NO. _____

CITY _____ STATE _____ ZIP CODE _____

MY NEW ADDRESS IS:

NEW ADDRESS _____ APT. NO. _____

CITY _____ STATE _____ ZIP CODE _____

Send this form to:

**Irbid Motorworks of America,
15411 NE 95th St.
Redmond, WA 98052**

**or fax to:
(425) 696 - 0834**

NEW OWNER FORM

If you purchase a Ural Motorcycle from somebody other than a dealer, please fill out this form and mail to the address below. This will insure that you receive all correspondence from Irbit Motorworks of America

VEHICLE IDENTIFICATION NUMBER

--	--	--	--	--	--	--	--	--	--	--	--	--	--	--	--	--	--	--	--

NEW OWNER'S NAME _____

ADDRESS _____ APT. NO. _____

CITY _____ STATE _____ ZIP CODE _____

DATE OF SALE _____

MO / DAY / YEAR

Purchased From _____

City _____ State _____ Zip Code _____

Send this form to:

**Irbit Motorworks of America,
15411 NE 95th St
Redmond, WA 98052**

**or fax to:
(425) 696 - 0834**

URAL - STARTING & RUNNING TIPS

Starting the Engine

1. Open carburetor enricheners on both carburetors (pull lever out) if temperature is below 50 degrees.
2. Make sure fuel petcock is open “ON” or prime “PRI”
3. Ignition “RUN,” “KILL,” switch set to “RUN” (down), gearbox in “NEUTRAL”.
4. Push starter button until engine fires, **OR...**
5. With foot on kick-starter lever, push foot down **swiftly and hard** open the throttle grip *slightly*. Repeat until engine fires (usually 2 or 3 kicks). Turn **OFF** enricheners.
6. Let the engine warm up for 1-3 minutes, depending on the temperature.
7. After the engine has warmed up, operate the motorcycle under moderate loads and speeds for several miles until the oil has circulated well and the engine and gearbox are functioning smoothly.

Trouble Shooting

If engine does not start with above method, the problem(s) may be one or more of the following:

1. Engine is “flooded,” i.e.; the spark plugs have been “fouled” by too much throttle (and fuel) and will not spark.

Correction: Flooding is corrected by removing the spark plugs and drying them.

2. Too little fuel is getting to the engine due to low fuel in tank and/or plugged fuel lines or fuel petcock.

Correction: Clogged fuel lines or filter are corrected by blowing through fuel lines from carburetor end to remove any debris from lines. Fuel petcock filter can be cleaned by removing and cleaning.

3. Little or no spark is available to the engine due to a low battery, (dim headlight), or loose ignition wires.

Correction: Dead battery is corrected by charging battery, loose or broken ignition wires are corrected by replacing broken wire(s) or by reconnecting wires at either the spark plug cap, the ignition module, or at the ignition coil under the front cover of the engine.

- *4. Not enough compression in the cylinders due to excessive wear or incorrect adjustment of valve(s).**

* item 4 above requires the attention of a qualified mechanic at your URAL dealer.

*****WARNING!...Reverse Gear Damage... WARNING!*****

Attempting to engage reverse gear while the motorcycle is moving may cause **SEVERE** damage to the gearbox and will void the warranty. Engage the reverse gear only when the motorcycle is completely stopped and is either in 1st gear or neutral.

Pre-Trip Check List

1. Check all lights and the horn for proper operation.
2. Check the brake and clutch levers and/or pedals.
3. Make sure all wheels and the final drive assemblies are securely fastened .
4. Check the carburetor flanges and air filter ducts for integrity and proper alignment.
5. Check the tire tread depth - should be greater than 1/8 inch.
6. Check the sidecar attachment mounts – all mounts should be securely tightened.

Gasoline level in the fully filled tank should be 10 - 15 mm / $\frac{1}{2}$ - $\frac{3}{4}$ in. below the lower edge of the tank filler. Do not overfill the tank.

See that the oil level in the engine crankcase is not higher than the top and not lower than the bottom marks on the dipstick with the filler plug undone. (See chapter 4 Lubrication System)

Here Are Some Helpful Publications To Help You With Your New Ural

Learning to Ride The Ural With Sidecar Accessory
Available through the Whitehorse Press
www.whitehorsepress.com

Weav's Useful Information and Technical Guide to Antique Russian Motorcycles and Sidecars
Available through Mike Weaver
threeweavers@earthlink.net
www.molotovmotors.com